

**Ersatzteilliste**  
**Spare Parts List**  
**Liste de pièces détachées**  
**Lista de piezas de repuesto**

8/99

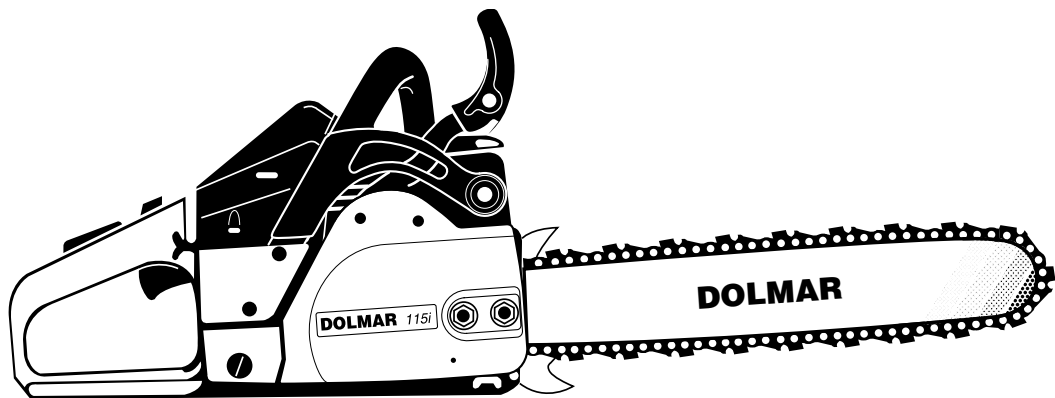

109	PS-43
109 HappyStart	PS-52
110i	PS-540
110i H	
111	
115	
115 H	
115i	
115i H	

---

**DOLMAR**



995 700 064 (D, GB, F, E)

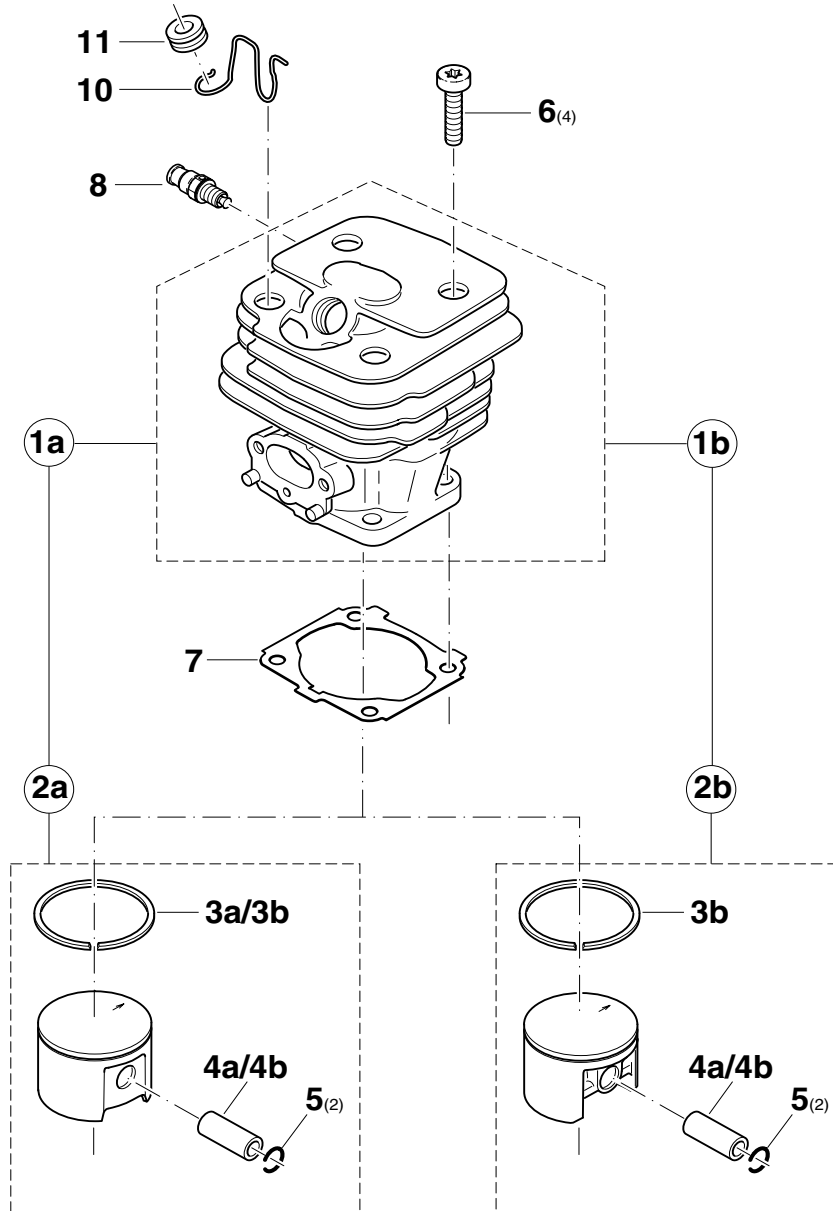



Pos.	Anz. Qty. Qté. Cdad.										Teil-Nr. Part No. No. de pièce No. de pieza	Hinweise Notes Renseign. Nota	Benennung	Description	Désignation	Denominación
	109	109	110	111	115	115	PS-43	PS-52	PS-540	HappyStart						
1a	1	1									020 130 030		Zylinder / Kolben kpl. ø 40	Cylinder / piston cpl.	Cylindre et piston cpl.	Cilíndro con piston, cpl.
1a		1									032 130 250		Zylinder / Kolben kpl. ø 40	Cylinder / piston cpl.	Cylindre et piston cpl.	Cilíndro con piston, cpl.
1a			1								026 130 000		Zylinder / Kolben kpl. ø 44	Cylinder / piston cpl.	Cylindre et piston cpl.	Cilíndro con piston, cpl.
1b				1	1						027 130 020		Zylinder / Kolben kpl. ø 44	Cylinder / piston cpl.	Cylindre et piston cpl.	Cilíndro con piston, cpl.
1b											033 130 010		Zylinder / Kolben kpl. ø 45	Cylinder / piston cpl.	Cylindre et piston cpl.	Cilíndro con piston, cpl.
2a	1	1	1								032 132 011		Kolben kpl. ø 40	Piston assy.	Piston cpl.	Pistón cpl.
2a			1								020 132 111		Kolben kpl. ø 44	Piston assy.	Piston cpl.	Pistón cpl.
2b				1	1						027 132 050		Kolben kpl. ø 44	Piston assy.	Piston cpl.	Pistón cpl.
2b											033 132 010		Kolben kpl. ø 45	Piston assy.	Piston cpl.	Pistón cpl.
3a	1	1	1								021 132 230		Kolbenring ø 40	Piston ring	Segment de piston	Segment de pistón
3b			1	1	1						027 132 020		Kolbenring ø 44	Piston ring	Segment de piston	Segment de pistón
3b											033 132 020	Corr.	Kolbenring ø 45	Piston ring	Segment de piston	Segment de pistón
4a	1	1	1	1							020 132 030		Kolbenbolzen ø 10/6 x 28	Piston pin	Axe de piston	Perno de pistón
4a					1						027 132 030		Kolbenbolzen ø 10/6 x 31	Piston pin	Axe de piston	Perno de pistón
4b	1	1	1	1	1	1	1	1	1		001 132 010	SI 5/96	Kolbenbolzen ø 10/6 x 30	Piston pin	Axe de piston	Perno de pistón
5	2	2	2	2	2	2	2	2	2		020 132 050		Sprengring	Spring ring	Anneau ressort	Anillo elástico
6	4	4	4	4	4	4	4	4	4		908 005 205		Schraube M5x20	Screw	Vis	Tornillo
7	1	1	1	1	1	1	1	1	1		965 525 041	=>	Dichtung	Gasket	Joint	Junta
7	1	1	1	1	1	1	1	1	1		965 525 042	<=	Dichtung	Gasket	Joint	Junta
8	1										001 131 150		Dekompressionsventil	Decompression valve	Soupape de décompress.	Válvula de décompress.
10	1	1	1	1	1	1	1	1	1		001 142 012		Klammer	Cramp	Crampon	Grampón
11	1	1	1	1	1	1	1	1	1		965 401 011		Gummitülle	Rubber bush	Passe-fil	Boquilla de caucho
													<b>Spezialteile für USA</b>	<b>Special parts for USA</b>	<b>Pièces spéciales pour USA</b>	<b>Piezas especiales por USA</b>
1b			1	1							027 130 030		Zylinder / Kolben kpl. ø 44	Cylinder / piston cpl.	Cylindre et piston cpl.	Cilíndro con piston, cpl.
2b			1	1							027 132 050		Kolben kpl. ø 44	Piston assy.	Piston cpl.	Pistón cpl.

109, 109 HappyStart  
 110i, 110i H  
 111  
 115, 115 H, 115i, 115i H  
 PS-43, PS-52, PS-540

# 3 a

Kurbelgehäuse  
 Crankcase  
 Carter- vilebrequin  
 Carter cigüeñal

**DOLMAR**

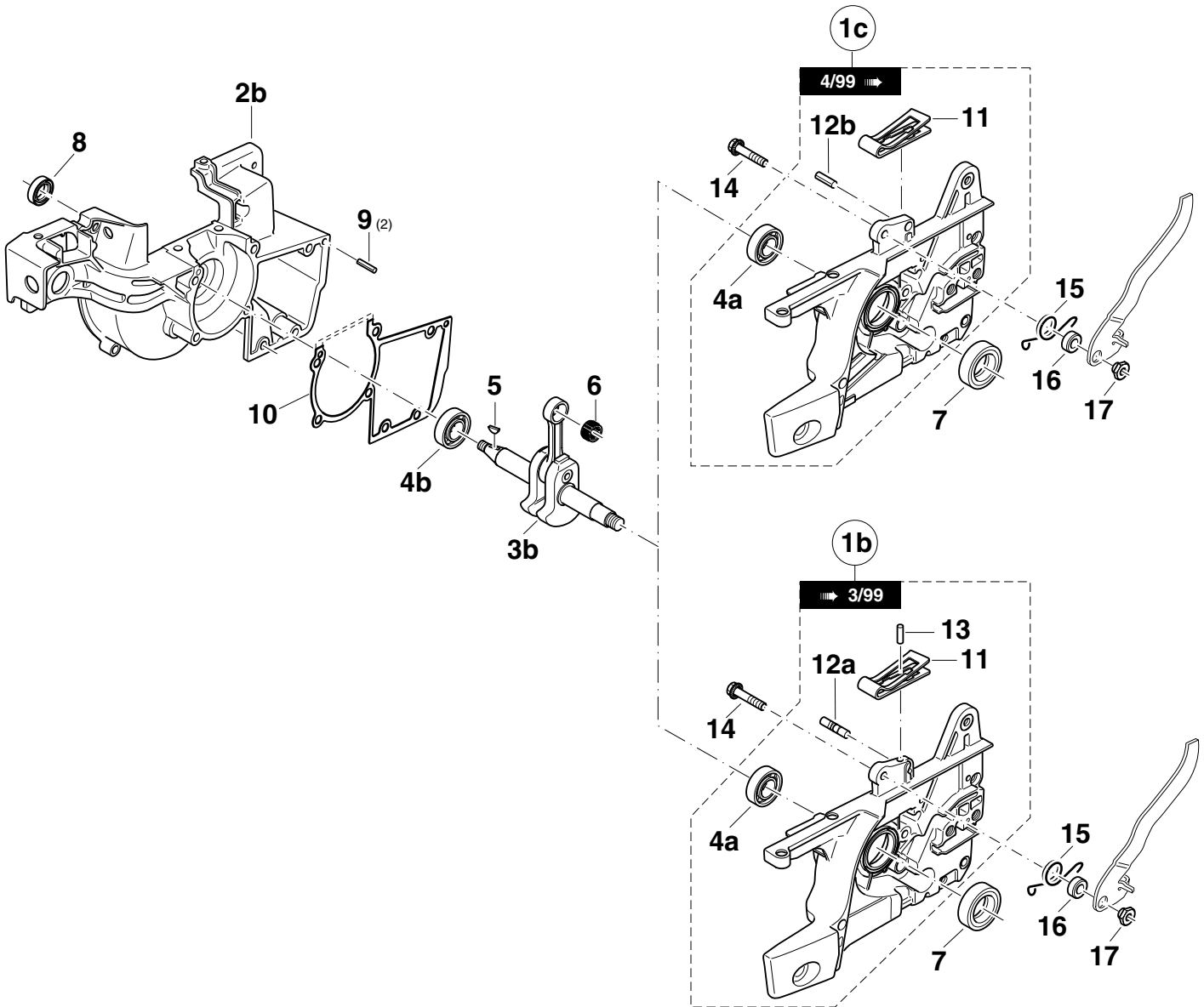

109 / PS-43: → 107932  
 110i: → 124759  
 111 / PS-52: → 161143  
 115i: → 185116

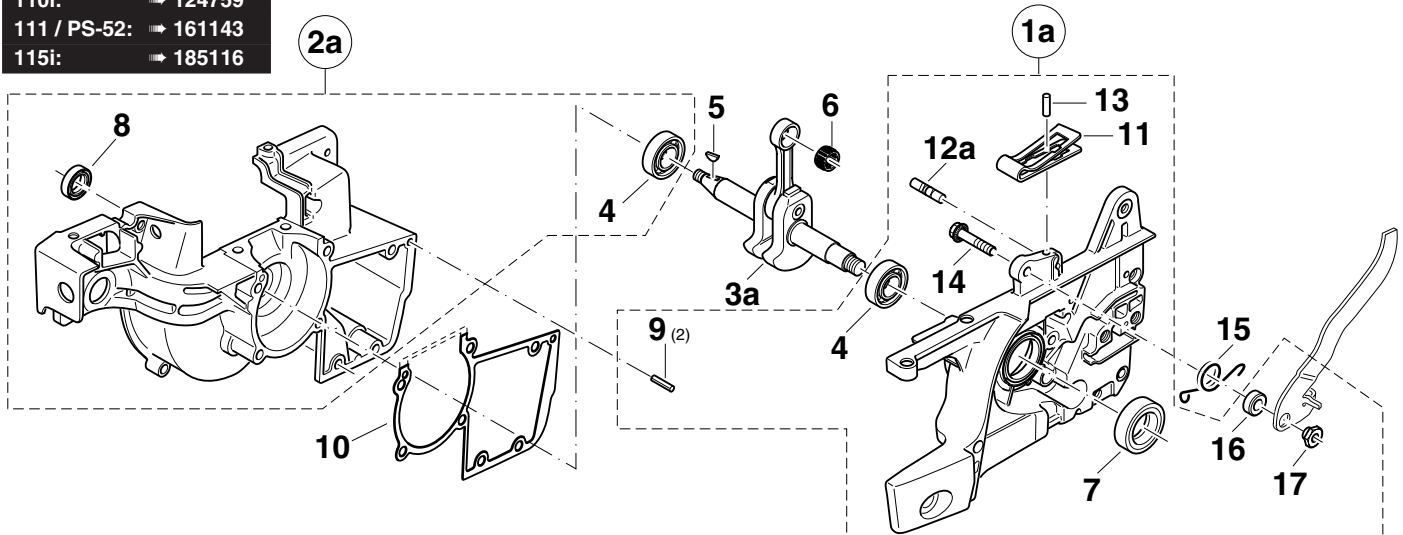



**3 a**

Kurbelgehäuse  
Crankcase  
Carter- vilebrequin  
Carter cigüeñal

Pos.	Anz. Qty. Qté. Cdad.										Teil-Nr. Part No. No. de pièce No. de pieza	Hinweise Notes Renseign. Nota	Benennung	Description	Désignation	Denominación
	109	109	110i	111	111	115	115i	PS-43	PS-52	PS-540						
1b	1	1	1	1	1	1	1	1	1	1	027 111 060	=>	Kurbelgehäuse KS kpl.	Crankcase cpl. (cl.)	Carter-coté embr. cpl.	Cárter cig., lado embr. cpl.
1c	1	1	1	1	1	1	1	1	1	1	020 111 260	<=>	Kurbelgehäuse KS kpl.	Crankcase cpl. (cl.)	Carter-coté embr. cpl.	Cárter cig., lado embr. cpl.
2b	1	1	1	1	1	1	1	1	1	1	027 111 030	=>	Kurbelgehäuse MS	Crankcase (mag.)	Carter-coté magn.	Cárter cig., lado magn.
2b	1	1	1	1	1	1	1	1	1	1	020 111 331	<=>	Kurbelgehäuse MS	Crankcase (mag.)	Carter-coté magn.	Cárter cig., lado magn.
3b	1	1	1	1	1	1	1	1	1	1	027 120 010	SI 10/93	Kurbelwelle	Crankshaft	Vilebrequin	Cigüeñal
4a	1	1	1	1	1	1	1	1	1	1	960 102 159	SI 10/93	Kugellager	Ball bearing	Roulement à billes	Rodamiento
4b	1	1	1	1	1	1	1	1	1	1	960 102 129	SI 10/93	Kugellager	Ball bearing	Roulement à billes	Rodamiento
5	1	1	1	1	1	1	1	1	1	1	939 620 371		Scheibenfeder	Key	Clavette	Chületa
6	1	1	1	1	1	1	1	1	1	1	962 211 030		Nadelkäfig	Needle cage	Cage à aiguilles	Jaula de agujas
7	1	1	1	1	1	1	1	1	1	1	962 900 052		Radialdichtring	Radial ring	Joint radial	Anillo radial
8	1	1	1	1	1	1	1	1	1	1	962 900 050		Radialdichtring	Radial ring	Joint radial	Anillo radial
9	2	2	2	2	2	2	2	2	2	2	936 430 160		Spiralspannstift 3x16	Spiral clamping pin	Goupille	Pasador
10	1	1	1	1	1	1	1	1	1	1	965 525 001	=>	Dichtung	Gasket	Joint	Junta
10	1	1	1	1	1	1	1	1	1	1	965 525 002	<=>	Dichtung	Gasket	Joint	Junta
11	1	1	1	1	1	1	1	1	1	1	027 213 320		Blattfeder	Leaf spring	Ressort	Muelle
12a	1	1	1	1	1	1	1	1	1	1	027 213 230	⇒ 3/99	Rastbolzen	Bolt	Boulon	Perno
12b	1	1	1	1	1	1	1	1	1	1	934 950 160	4/99 ⇒	Spannhülse 5x16	Clamping sleeve	Douille de serrage	Casquillo tensor
13	1	1	1	1	1	1	1	1	1	1	934 930 100	⇒ 3/99	Spannhülse 3x10	Clamping sleeve	Douille de serrage	Casquillo tensor
14	1	1	1	1	1	1	1	1	1	1	027 213 520		6kt-Schraube mit Bund	Hexagonal head screw	Vis hexagonal	Tornillo hex.
15	1	1	1	1	1	1	1	1	1	1	027 213 270		Feder	Spring	Ressort	Muelle
16	1	1	1	1	1	1	1	1	1	1	027 213 510		Ring	Ring	Bague	Anillo
17	1	1	1	1	1	1	1	1	1	1	027 213 500		Ansatzmutter	Shoulder nut	Ecrou	Tuerca
<b>109 / PS-43: ⇒ 107932    110i: ⇒ 124759    111 / PS-52: ⇒ 161143    115i: ⇒ 185116</b>																
1a	1	1	1	1	1	1	1	1	1	1	027 111 102		Kurbelgehäuse KS kpl.	Crankcase cpl. (cl.)	Carter-coté embr. cpl.	Cárter cig., lado embr. cpl.
2a	1	1	1	1	1	1	1	1	1	1	020 111 203		Kurbelgehäuse MS kpl.	Crankcase cpl. (mag.)	Carter-coté magn. cpl.	Cárter cig., lado magn. cpl.
3a	1	1	1	1	1	1	1	1	1	1	020 120 010		Kurbelwelle	Crankshaft	Vilebrequin	Cigüeñal
4	2	2	2	2	2	2	2	2	2	2	960 622 150		Rollenhülse	Roller bearing	Roulement à rouleaux	Rodamiento

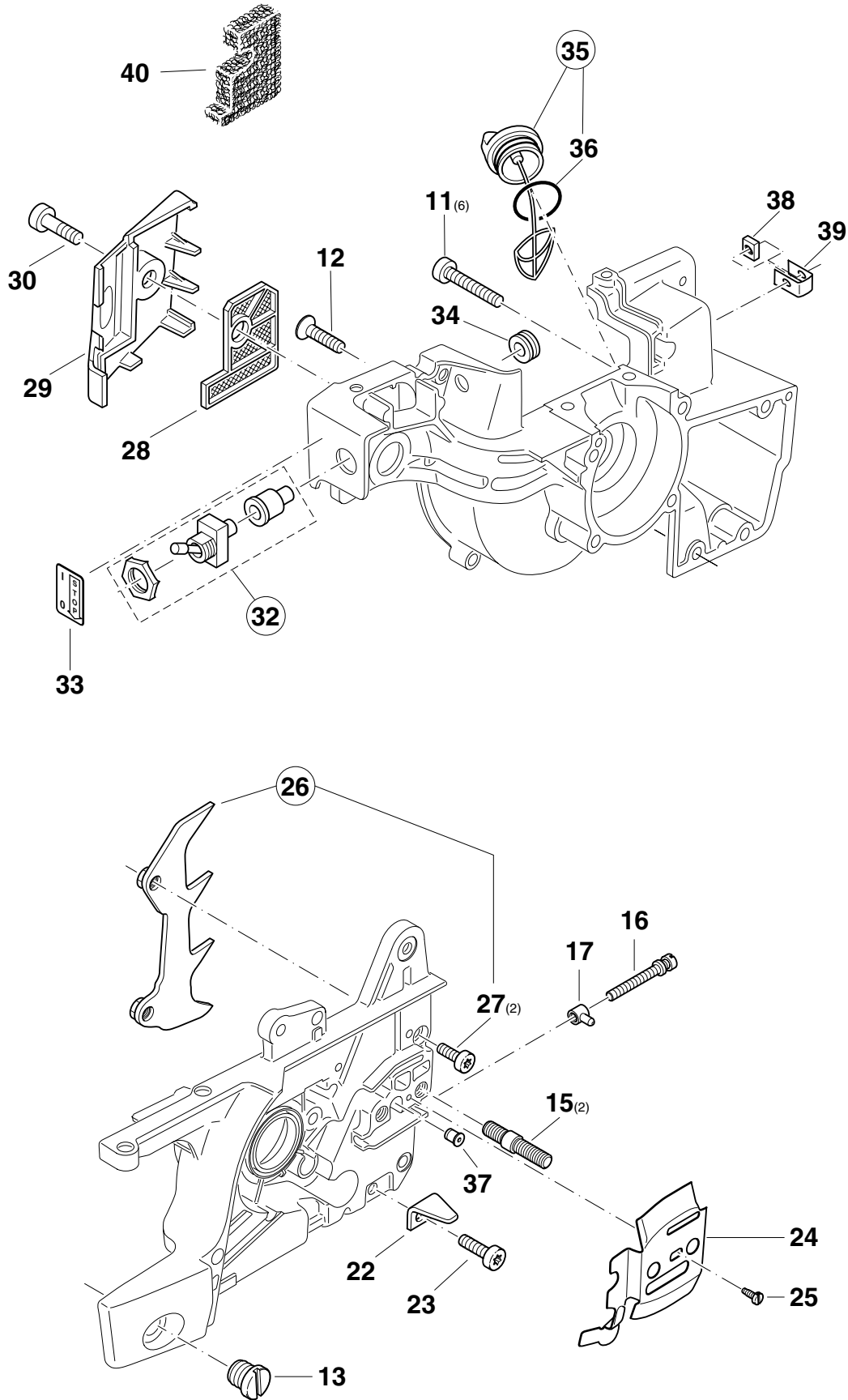





# 3 b

Kurbelgehäuse  
Crankcase  
Carter- vilebrequin  
Carter cigüeñal

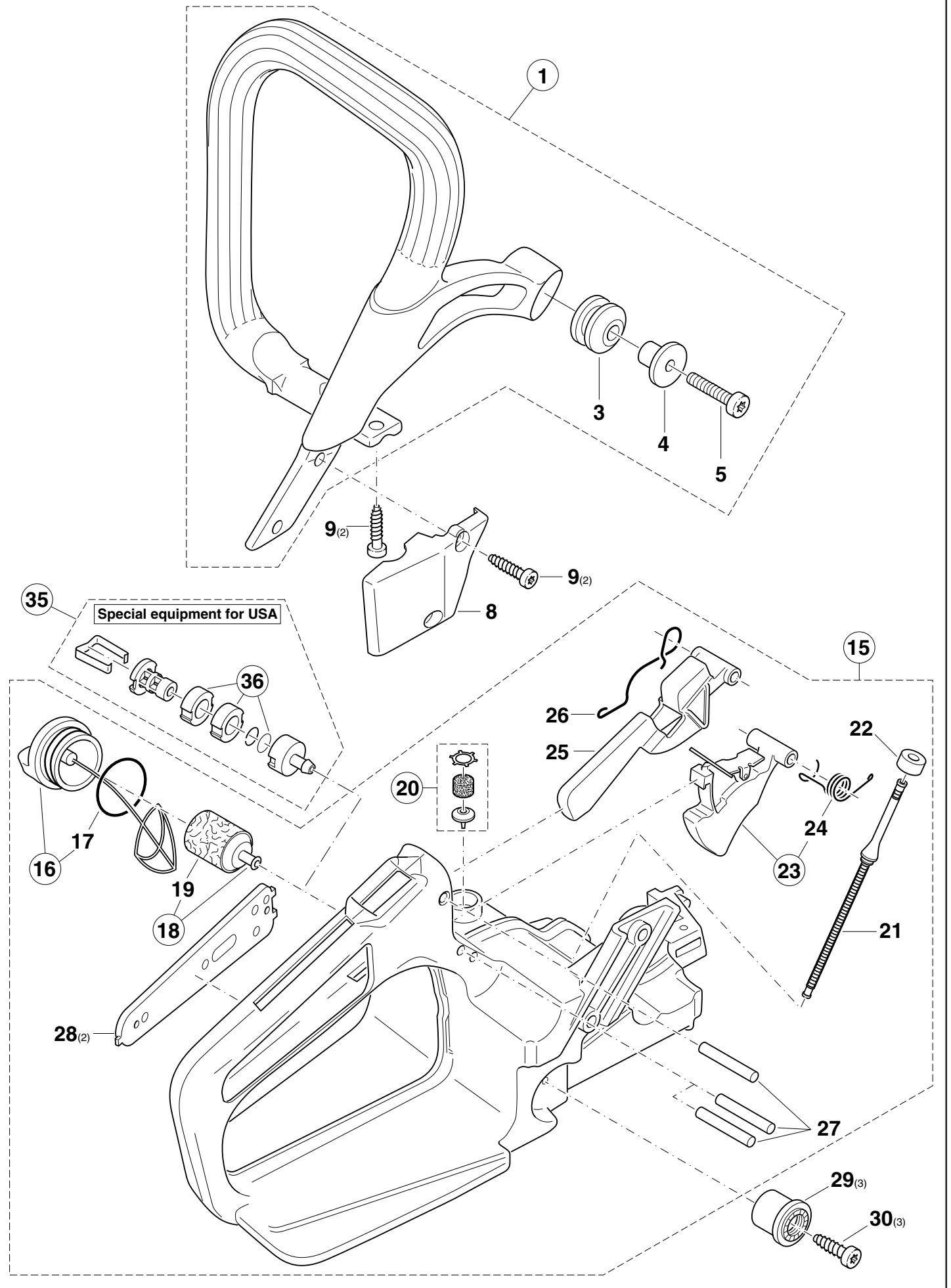
Pos.	Anz. Qty. Qté. Cdad.								Teil-Nr. Part No. No. de pièce No. de pieza	Hinweise Notes Renseign. Nota	Benennung	Description	Désignation	Denominación
	109	109	110	111	115	115	PS-43	PS-52						
11	6	6	6	6	6	6	6	6	908 005 305		Schraube ⚙ M5x30	Screw	Vis	Tornillo
12	1	1	1	1	1	1	1	1	908 105 204		Senkschraube ⚙ M5x20	Countersunk screw	Vis fraisée	Tornillo plano
13	3	3	3	3	3	3	3	3	001 111 011		Spezialschraube M12x1	Special screw	Vis spéciale	Tornillo especial
15	2	2	2	2	2	2	2	2	905 808 305		Stiftschraube M8x30	Gudgeon	Goujon fileté	Prisionero
16	1	1	1	1	1	1	1	1	389 213 080		Spannschraube	Tensioning screw	Vis de tension	Tornillo de tensión
17	1	1	1	1	1	1	1	1	001 213 020		Mutter mit Zapfen	Nut with pivot	Ecrou avec pivot	Tuerca con espiga
22	1	1	1	1	1	1	1	1	020 111 082		Kettenfänger	Chain catch	Arrêt-chaîne	Bulón de retención
23	1	1	1	1	1	1	1	1	908 005 125		Schraube ⚙ M5x12	Screw	Vis	Tornillo
24	1	1	1	1	1	1	1	1	020 111 172		Führungsblech	Guide plate	Tôle de guidage	Chapa protectora
25	1	1	1	1	1	1	1	1	915 135 100		Schraube 3,5x9,5	Screw	Vis	Tornillo
26	1	1	1	1	1	1	1	1	020 250 020		Zackenleiste kpl.	Spike bar assy.	Barre dentée cpl.	Barra dentada cpl.
27	2	2	2	2	2	2	2	2	908 005 095		Schraube ⚙ M5x9	Screw	Vis	Tornillo
28	1	1	1	1	1	1	1	1	020 173 011		Vorfilter	Prefilter	Prefiltre	Prefiltro
29	1	1	1	1	1	1	1	1	020 173 023		Deckel für Vorfilter	Cover for prefilter	Couvercle p. prefiltre	Tapa p. prefiltro
30	1	1	1	1	1	1	1	1	908 605 145		Schlitz-Schraube ⚙M5x14	Fillister head screw	Vis cylindrique	Tornillo cilíndrico
32	1	1	1	1	1	1	1	1	957 605 112		Kurzschlußschalter kpl.	Short-circuit switch cpl.	Interrupt. court-circuit cpl.	Interrupt. corto-circuite
33	1	1	1	1	1	1	1	1	980 113 841		Schild	Label	Plaque	Placa
34	1	1	1	1	1	1	1	1	965 401 011		Gummitülle	Rubber bush	Passe-fil	Boquilla de caucho
35	1	1	1	1	1	1	1	1	010 114 031		Öltankverschluß kpl.	Oil tank plug assy.	Bouchon res. d' huile cpl.	Cierre depósito aceite cpl.
36	1	1	1	1	1	1	1	1	963 100 050		Dichtung	Gasket	Joint	Junta
37	1	1	1	1	1	1	1	1	010 245 010		Belüftungsventil	Vent valve	Soupape d' aération	Válvula ventilación
38	1	1	1	1	1	1	1	1	923 305 000		4kt-Mutter	Square nut	Ecrou carré	Tuerca cuadrada
39	1	1	1	1	1	1	1	1	020 111 070		Klammer	Cramp	Crampon	Grampón
											<b>Zubehör (nicht im Lieferumfang)</b>	<b>Accessories (not incl. in delivery)</b>	<b>Accessoires (non incl. dans la livraison)</b>	<b>Accesorios (no incluidos en entrega)</b>
40	1	1	1	1	1	1	1	1	020 173 061		Schneefilter	Snow filter	Filtre a neige	Filtro de nieve





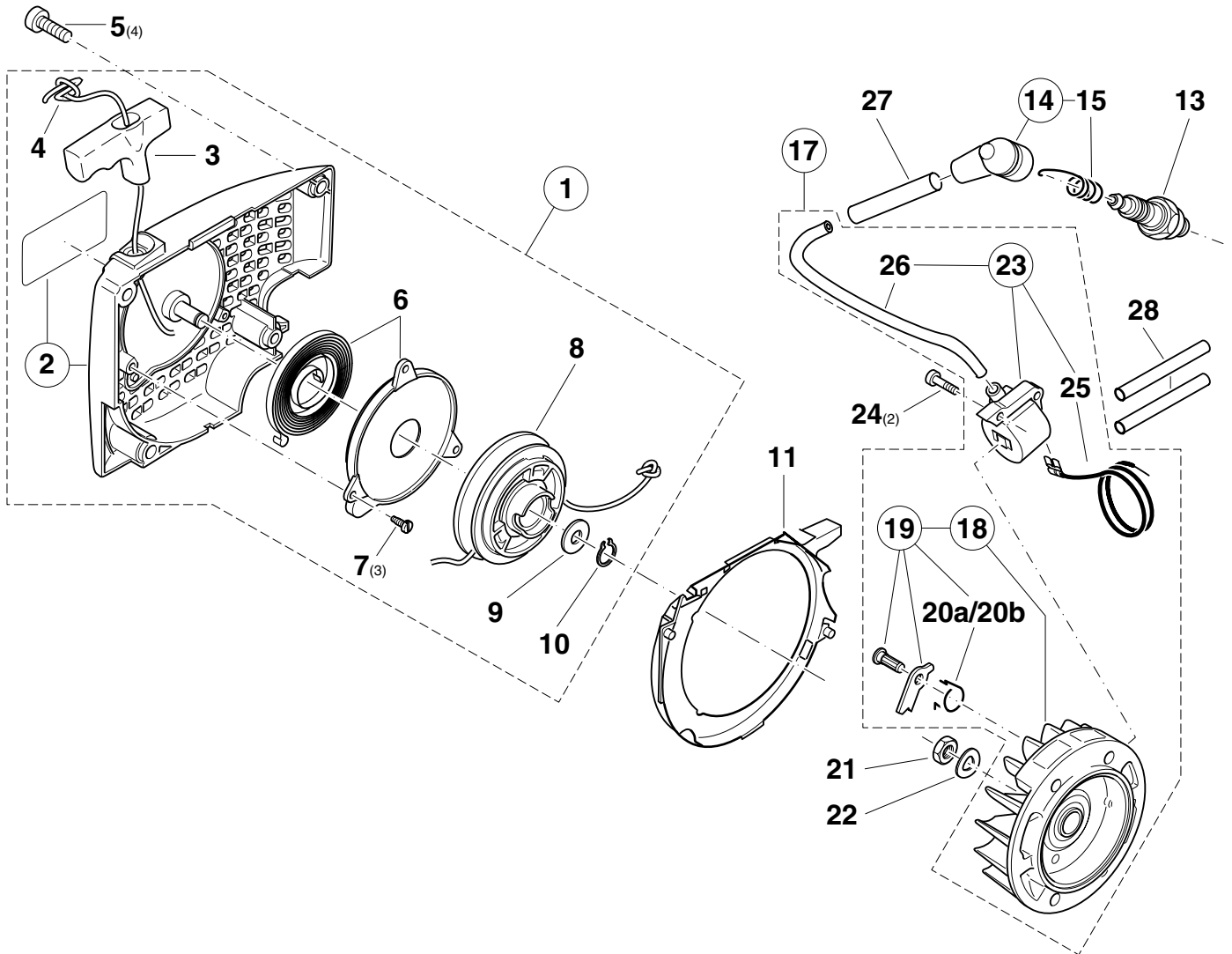

										4	<b>Kraftstofftank, Bügelgriff</b> <b>Fuel tank, tubular grip</b> <b>Réserv. carburant, poignée tubulaire</b> <b>Depósito de combustible, mango tubular</b>				
Pos.	Anz. Qty. Qté. Cdad.									Teil-Nr. Part No. No. de pièce No. de pieza	Hinweise Notes Renseign. Nota	Benennung	Description	Désignation	Denominación
	109	109	110	111	115	PS-43	PS-52	PS-540							
1	1	1	1	1	1	1	1	1	1	957 310 027	SI 5/96	Bügelgriff kpl.	Tubular handle assy.	Poignée tubulaire cpl.	Mango tubular cpl.
3	1	1	1	1	1	1	1	1	1	965 403 490		Schwingungsdämpfer	Rubber buffer	Amortisseur	Amortiguador
4	1	1	1	1	1	1	1	1	1	021 114 051		Befestigungsbuchse	Fixing bush	Douille de fixation	Casquillo de ajuste
5	1	1	1	1	1	1	1	1	1	908 005 305		Schraube $\odot$ M5x30	Screw	Vis	Tornillo
8	1	1	1	1	1	1	1	1	1	020 310 013		Abdeckung	Cover	Cache	Tapa
9	4	4	4	4	4	4	4	4	4	913 455 164		Schraube $\odot$ 5,5x16	Screw	Vis	Tornillo
15	1	1	1	1	1	1	1	1	1	020 114 004		Tank kpl.	Tank assy.	Réservoir cpl.	Depósito cpl.
16	1	1	1	1	1	1	1	1	1	965 451 900	=>	Tankverschluß kpl. (Kraftst.)	Tank plug assy. (fuel)	Bouchon réserv. cpl. (carb.)	Cierre de depó. cpl. (comb.)
16	1	1	1	1	1	1	1	1	1	965 451 901	<=	Tankverschluß kpl. (Kraftst.)	Tank plug assy. (fuel)	Bouchon réserv. cpl. (carb.)	Cierre de depó. cpl. (comb.)
17	1	1	1	1	1	1	1	1	1	963 232 045	Corr.	O-Ring $\varnothing$ 31x4,5	Packing ring	Bague-joint	Anillo de guarnición
18	1	1	1	1	1	1	1	1	1	963 601 120		Saugkopf	Suction head	Tête d'aspiration	Cabeza de aspiración
19	1	1	1	1	1	1	1	1	1	963 601 240		Filz	Felt	Feutre	Filtro
20	1	1	1	1	1	1	1	1	1	957 114 010		Belüftungsventil kpl.	Vent valve cpl.	Soupape d'aération cpl.	Válvula ventilación cpl.
21	1	1	1	1	1	1	1	1	1	965 404 460		Kraftstoffleitung	Fuel line	Conduite carb.	Conducto combu.
22	1	1	1	1	1	1	1	1	1	965 404 520		Dichtung	Gasket	Joint	Junta
23	1	1	1	1	1	1	1	1	1	020 117 290		Gashebel / Gasgestänge kpl.	Throttle lever / linkage cpl.	Levier d'accélération cpl.	Acelerador c. varilla cpl.
24	1	1	1	1	1	1	1	1	1	020 117 273		Drehfeder	Spring	Ressort	Muelle
25	1	1	1	1	1	1	1	1	1	020 117 301		Rasthebel	Catch lever	Levier de verrouillage	Palanca trincada
26	1	1	1	1	1	1	1	1	1	020 117 160		Biegefeder	Bend spring	Ressort	Muelle
27	3	3	3	3	3	3	3	3	3	935 932 320		Zylinderstift	Cylindrical pin	Goupille cylindrique	Prisionero
28	2	2	2	2	2	2	2	2	2	020 114 051		Griffschale	Grip plate	Plaque de poignée	Chapa de mango
29	3	3	3	3	3	3	3	3	3	965 403 280	SI 7/94	Schwingungsdämpfer	Rubber buffer	Amortisseur	Amortiguador
30	3	3	3	3	3	3	3	3	3	913 447 134		Schraube $\odot$ 4,7x13	Screw	Vis	Tornillo
												<b>Spezialteile für USA</b>	<b>Special parts for USA</b>	<b>Pièces spéciales pour USA</b>	<b>Piezas especiales por USA</b>
35	1	1								010 114 010		Saugkopf	Suction head	Tête d'aspiration	Cabeza de aspiración
36	1	1								010 114 020		Rep.-Satz, Filter (je 5 Stck.)	Rep. kit, filter (5 of each)	Jeu de réparat., filtre	Juego de reparar, filtro



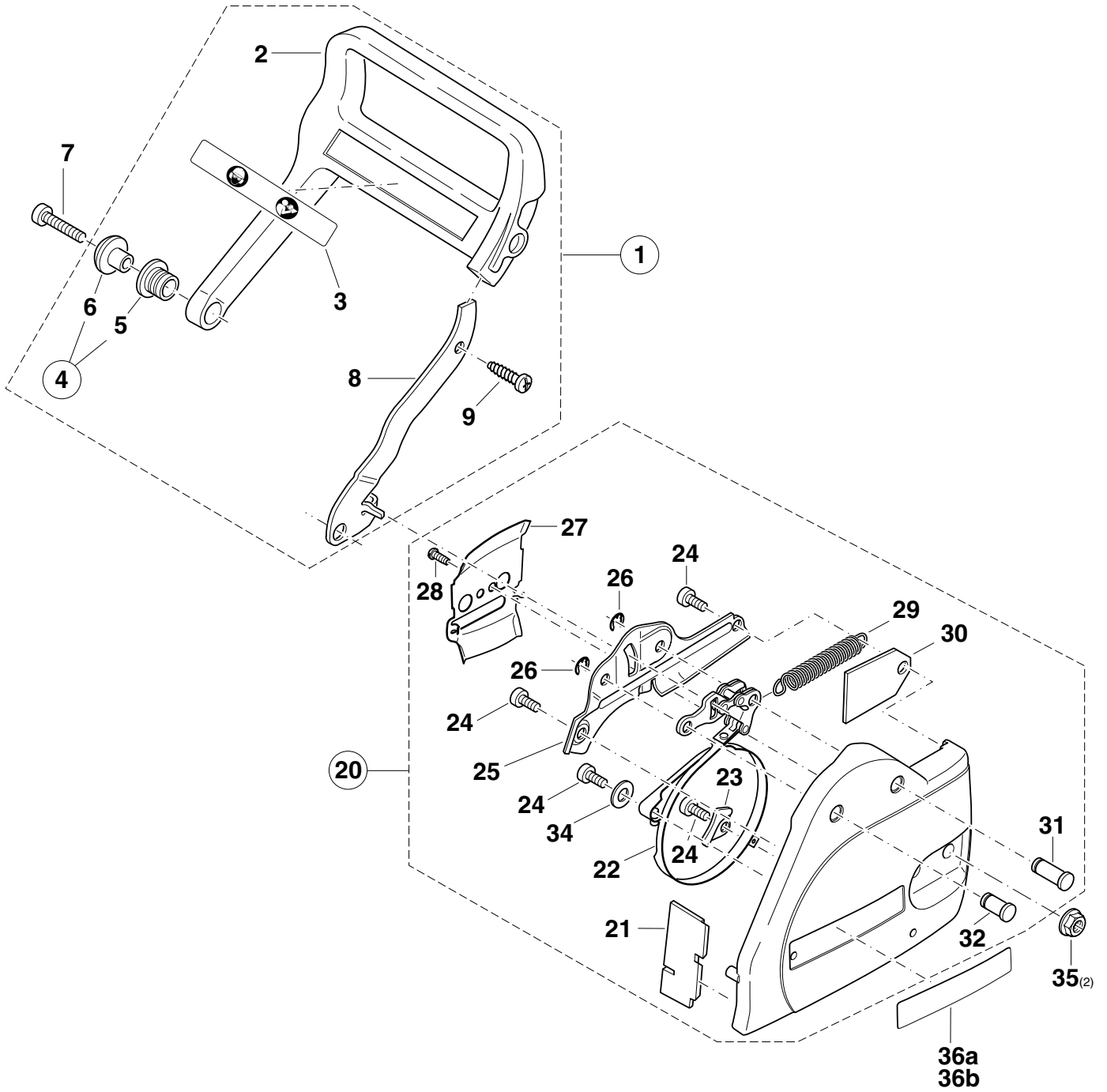

										<b>5</b>	<b>Zündelektronik, Anwerfvorrichtung</b> <b>Ignition electronics, starter</b> <b>Allumage électronique, dispositif de démarrage</b> <b>Bobina encendido, dispositivo de arranque</b>			<b>DOLMAR</b> 	
Pos.	Anz. Qty. Qté. Cdad.									Teil-Nr. Part No. No. de pièce No. de pieza	Hinweise Notes Renseign. Nota	Benennung	Description	Désignation	Denominación
	109	109	110	111	115	PS-43	PS-52	PS-540							
1	1	1	1	1	1	1	1	1	1	027 160 010		Anwerfvorrichtung kpl.	Starter assy.	Dispos. de démarrage cpl.	Dispos. de arranque cpl.
2	1	1	1	1	1	1	1	1	1	020 112 180		Ventilatorgehäuse kpl.	Fan housing cpl.	Carter de ventilateur cpl.	Cárter de ventilador cpl.
3	1	1	1	1	1	1	1	1	1	965 402 262		Anwerfgriff	Starter grip	Poignée de lancement	Tirador de arranque
4	1	1	1	1	1	1	1	1	1	108 164 020		Anwerfseil ø3,5 x 980 mm	Starter rope	Câble de démarrage	Cordón de arranque
4	1	1	1	1	1	1	1	1	1	985 000 155		Anwerfseil ø3,5 x 100 m	Starter rope	Câble de démarrage	Cordón de arranque
5	4	4	4	4	4	4	4	4	4	908 005 165		Schraube M5x16	Screw	Vis	Tornillo
6	1	1	1	1	1	1	1	1	1	020 163 031		Rückholfeder im Gehäuse	Rewind spring in hous.	Ressort rappel dans boît	Resorte retenc. en caja
7	3	3	3	3	3	3	3	3	3	915 135 100		Blechschraube 3,5x9,5	Screw	Vis	Tornillo
8	1	1	1	1	1	1	1	1	1	027 162 070		Seiltrommel	Cable drum	Tamb. de cable	Tamb. p. cordón
9	1	1	1	1	1	1	1	1	1	924 108 400		Scheibe	Disc	Disque	Arandela
10	1	1	1	1	1	1	1	1	1	929 108 080		Sicherungsring	Safety disc	Rondelle sécurite	Arandela seguridad
11	1	1	1	1	1	1	1	1	1	020 112 010		Luftführung	Air duct	Plaque de ventilation	Placa ventilación
13	1	1	1	1	1	1	1	1	1	965 603 021		Zündkerze	Spark plug	Bougie	Bujía
14	1	1	1	1	1	1	1	1	1	957 604 260		Zündkerzenstecker kpl.	Plug cap assy.	Fiche de bougie cpl.	Tapa bujía cpl.
15	1	1	1	1	1	1	1	1	1	965 604 180		Feder	Spring	Ressort	Muelle
17	1	1	1	1	1	1	1	1	1	027 140 000		Magnetzünder kpl.	Ignition assy.	Volant magn. cpl.	Disp. encend. magn. cpl.
18	1	1	1	1	1	1	1	1	1	027 141 020	SI 5/96	Polrad kpl.	Flywheel assy.	Roue polaire cpl.	Volante encend.
19	1	1	1	1	1	1	1	1	1	108 166 051		Anwerfklinke kpl.	Starter ratchet assy.	Cliquet cpl.	Trinquete arranque cpl.
20a	2	2	2	2	2	2	2	2	2	122 166 020		Drehfeder ø 12,8	Spring	Ressort	Muelle
20b	2	2	2	2	2	2	2	2	2	108 166 021		Drehfeder ø 16	Spring	Ressort	Muelle
21	1	1	1	1	1	1	1	1	1	920 308 024		6kt-Mutter M8x1	Hexagonal nut	Ecrou hexagonal	Tuerca hexagonal
22	1	1	1	1	1	1	1	1	1	928 308 001		Federscheibe	Spring washer	Rondelle ressort	Arandela presión
23	1	1	1	1	1	1	1	1	1	020 143 030	SI 9/91	Zündanker kpl. (Ducati)	Ignition coil cpl.	Bobine d' allum. cpl.	Bobina encend. cpl.
23	1	1	1	1	1	1	1	1	1	020 143 040	SI 9/91	Zündanker kpl. (Prüfref)	Ignition coil cpl.	Bobine d' allum. cpl.	Bobina encend. cpl.
24	2	2	2	2	2	2	2	2	2	908 605 205		Schlitz-Schraube M5x20	Screw	Vis	Tornillo
25	1	1	1	1	1	1	1	1	1	001 147 000		Kurzschlußkabel (Ducati)	Short-circuit cable	Câble court-circuit	Cable corto-circ.
26										970 310 200		Zündleitung 180 mm	Ignition cable	Câble d' allum.	Cable encend.
27										970 502 110		Isolierschlauch 48 mm	Insulating hose	Gaine isolante	Mango aislante
28										970 502 050		Isolierschlauch 100 mm	Insulating hose	Gaine isolante	Mango aislante

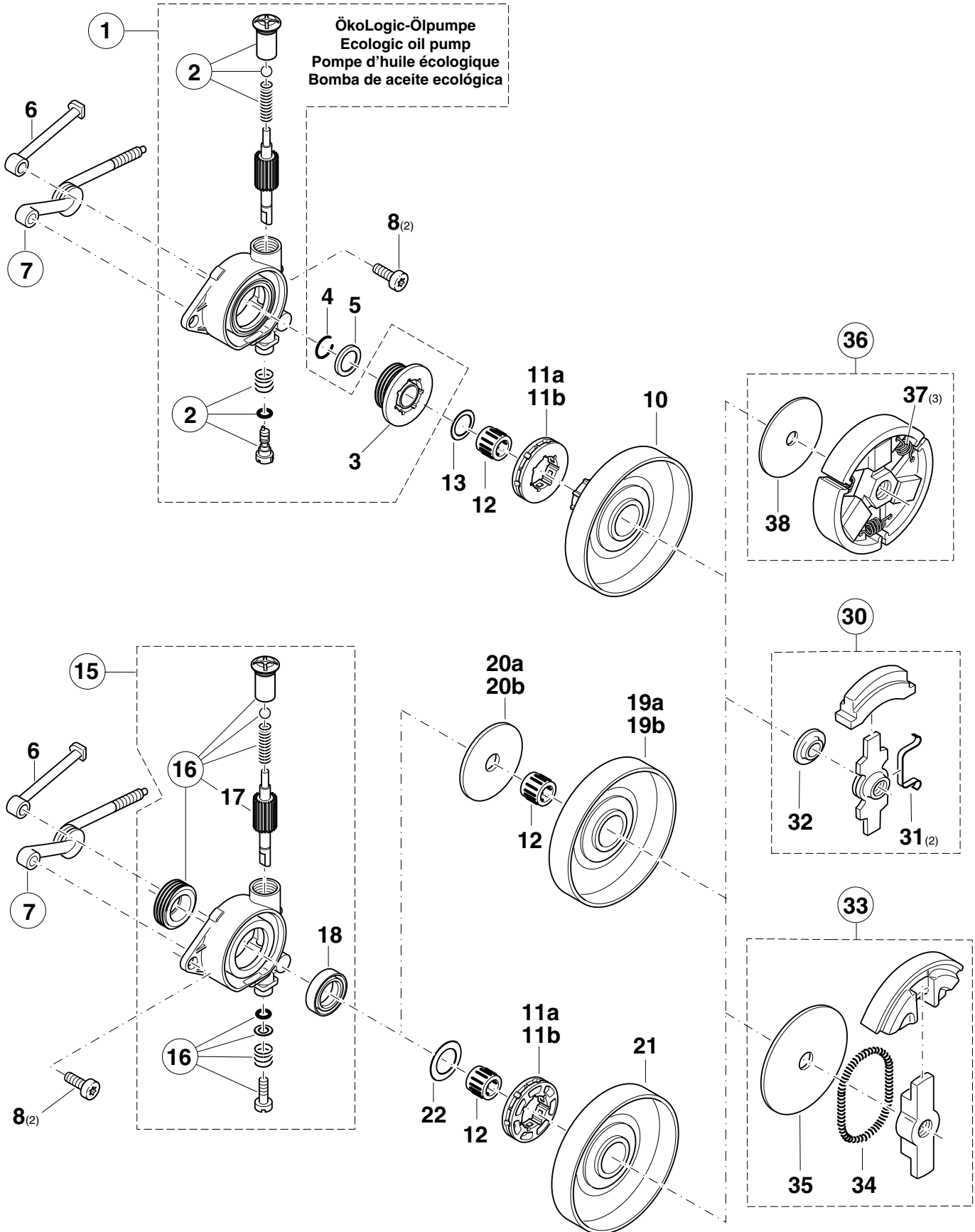

										<b>6</b>		<b>Kettenbremse, Handschutz</b> <b>Chain brake, hand guard</b> <b>Frein de chaîne, protège-main</b> <b>Freno de cadena, protector de mano</b>				
Pos.	Anz. Qty. Qté. Cdad.									Teil-Nr. Part No. No. de pièce No. de pieza	Hinweise Notes Renseign. Nota	Benennung	Description	Désignation	Denominación	
	109	109	110i	111	115	115i	PS-43	PS-52	PS-540							
1	1	1	1	1	1	1	1	1	1	027 213 452		Handschutz kpl.	Hand guard cpl.	Protège-main cpl.	Prot. de mano cpl.	
2	1	1	1	1	1	1	1	1	1	027 213 462		Handschutz	Hand guard	Protège-main	Prot. de mano	
3	1	1	1	1	1	1	1	1	1	980 114 237		Schild	Label	Plaque	Calcomania	
4	1	1	1	1	1	1	1	1	1	027 213 430		Satz Buchsen	Bushing set	Jeu de duille	Juego de casquillo	
5	1	1	1	1	1	1	1	1	1	027 213 150		Gummibuchse	Rubber bush	Duille caoutchouc	Casquillo de caucho	
6	1	1	1	1	1	1	1	1	1	027 213 161		Buchse	Bush	Duille	Casquillo	
7	1	1	1	1	1	1	1	1	1	908 005 205		Schraube $\odot$ M5x20	Screw	Vis	Tornillo	
8	1	1	1	1	1	1	1	1	1	027 213 221		Ausrückhebel	Disengaging lever	Levier de tension	Pasador de tensión	
9	1	1	1	1	1	1	1	1	1	905 005 184		Linsenschraube 5,5x18	Screw	Vis	Tornillo	
20	1	1	1	1	1	1	1	1	1	027 213 570	=>	Kettenbremse kpl.	Chain brake assy.	Frein de chaîne cpl.	Freno de cadena cpl.	
20	1	1	1	1	1	1	1	1	1	027 213 571	<=	Kettenbremse kpl.	Chain brake assy.	Frein de chaîne cpl.	Freno de cadena cpl.	
21	1	1	1	1	1	1	1	1	1	027 213 280		Schutzplatte	Protection cover	Couvercle protection	Chapa protectora	
22	1	1	1	1	1	1	1	1	1	027 213 050		Bremsband kpl.	Brake spring cpl.	Frein cpl.	Cinta de freno cpl.	
23	1	1	1	1	1	1	1	1	1	027 213 350		Bremsbandhalterung	Brake band holder	Tôle d'arrêt du frein	Soporte cinta freno	
24	4	4	4	4	4	4	4	4	4	913 205 125		Linsenschraube $\odot$ M5x12	Screw	Vis	Tornillo	
25	1	1	1	1	1	1	1	1	1	027 213 111		Abdeckplatte	Cover plate	Plaque de recouvrement	Tapa	
26	2	2	2	2	2	2	2	2	2	927 304 000		Sicherungsscheibe	Safety disc	Disque sécurité	Arandela seguridad	
27	1	1	1	1	1	1	1	1	1	027 111 040	=>	Führungsblech	Guide plate	Tôle de guidage	Chapa protectora	
27	1	1	1	1	1	1	1	1	1	027 111 041	<=	Führungsblech	Guide plate	Tôle de guidage	Chapa protectora	
28	1	1	1	1	1	1	1	1	1	915 135 100		Schraube 3,5x9,5	Screw	Vis	Tornillo	
29	1	1	1	1	1	1	1	1	1	027 213 120		Feder	Spring	Ressort	Muelle	
30	1	1	1	1	1	1	1	1	1	027 213 560		Gummiplatte	Rubber plate	Plaque de caoutchouc	Plancha de caucho	
31	1	1	1	1	1	1	1	1	1	027 213 130		Achse für Bremshebel	Shaft for brake lever	Axe de levier de frein	Eje palanca de freno	
32	1	1	1	1	1	1	1	1	1	027 213 140		Achse für Kniehebel	Shaft for lever	Axe de levier	Eje palanca	
34	1	1	1	1	1	1	1	1	1	924 500 049		Scheibe	Disc	Disque	Arandela	
35	2	2	2	2	2	2	2	2	2	923 208 004		6kt-Mutter mit Bund M8	Hexagonal nut	Ecrou hexagonal	Tuerca hexagonal	
36a	1	1								980 114 132		Schild (106 mm) 109	Label	Plaque	Calcomania	
36a		1								980 114 133		Schild (106 mm) 110i	Label	Plaque	Calcomania	
36a			1							980 114 134		Schild (106 mm) 111	Label	Plaque	Calcomania	
36a				1						980 114 218		Schild (106 mm) 111i	Label	Plaque	Calcomania	
36a					1					980 114 135		Schild (106 mm) 115i	Label	Plaque	Calcomania	
36b	1	1								980 114 381	SI 5/96	Schild (82,5 mm) 109	Label	Plaque	Calcomania	
36b		1								980 114 382	SI 5/96	Schild (82,5 mm) 110i	Label	Plaque	Calcomania	
36b			1							980 114 384	SI 5/96	Schild (82,5 mm) 111	Label	Plaque	Calcomania	
36b				1						980 114 385	SI 5/96	Schild (82,5 mm) 111i	Label	Plaque	Calcomania	
36b					1					980 114 754		Schild (82,5 mm) 115	Label	Plaque	Calcomania	
36b						1				980 114 386	SI 5/96	Schild (82,5 mm) 115i	Label	Plaque	Calcomania	
36b							1			980 114 380		Schild (82,5 mm) PS-43	Label	Plaque	Calcomania	
36b								1		980 114 383		Schild (82,5 mm) PS-52	Label	Plaque	Calcomania	
36b									1	980 114 736		Schild (82,5 mm) PS-540	Label	Plaque	Calcomania	



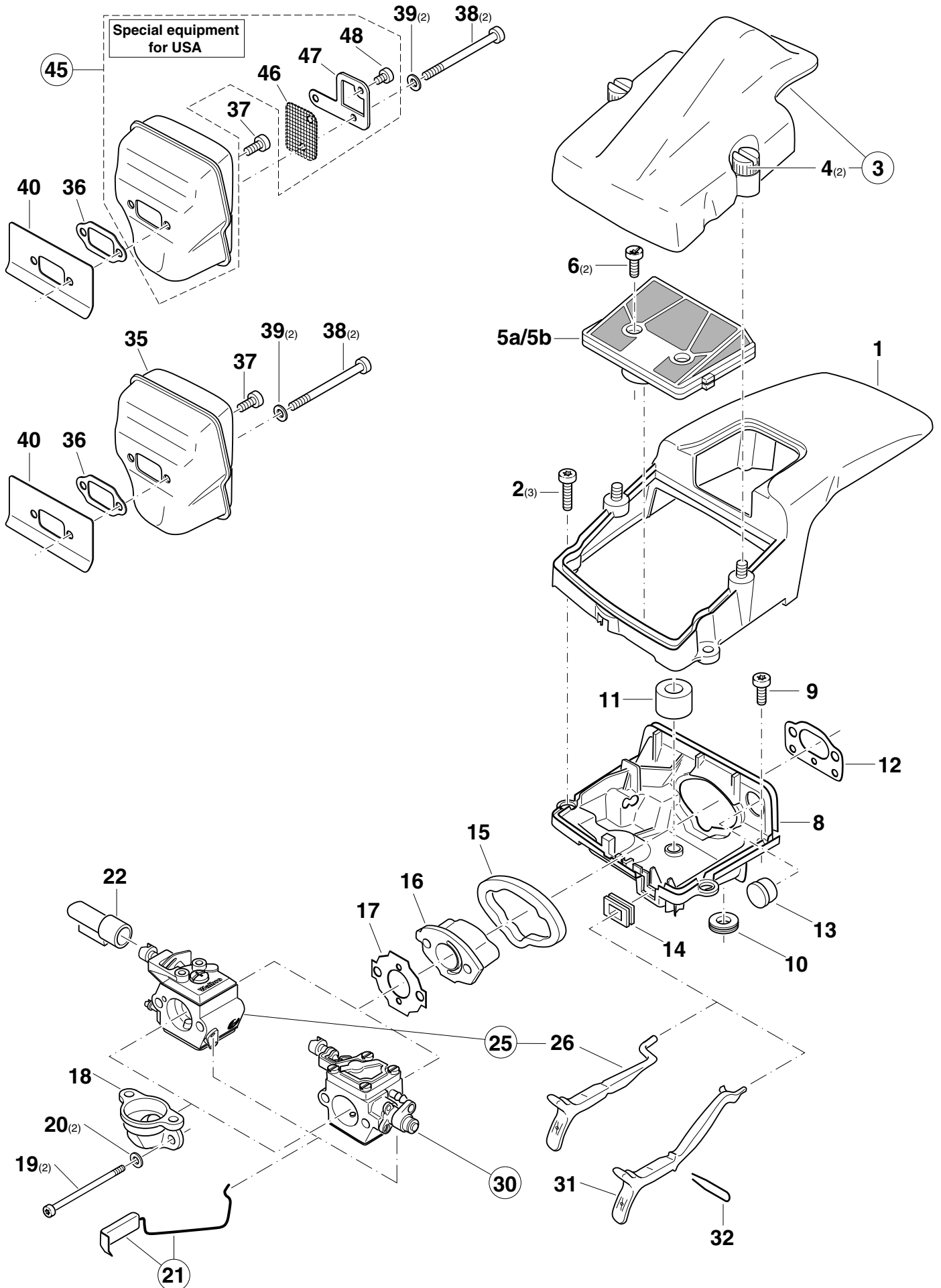

										7	Ölpumpe, Kupplung Oil pump, clutch Pompe à huile, embrayage Bomba de aceite, embrague					
Pos.	Anz. Qty. Qté. Cdad.										Teil-Nr. Part No. No. de pièce No. de pieza	Hinweise Notes Renseign. Nota	Benennung	Description	Désignation	Denominación
<div style="display: flex; justify-content: space-between;"> <span>109 HappyStart 109 HappyStart 1101 111 115 115f PS-43 PS-52 PS-540</span> </div>																
<b>ÖkoLogic-Ölpumpe      Ecologic oil pump      Pompe d'huile écologique      Bomba de aceite ecológ.</b>																
1	1	1	1	1	1	1	1	1	1	1	027 245 160	SI 5/95	Ölpumpe kpl.	Oil pump cpl.	Pompe à huile cpl.	Bomba de aceite cpl.
2	1	1	1	1	1	1	1	1	1	1	030 245 070		Reparatursatz kpl.	Repair kit cpl.	Jeu de réparation cpl.	Juego de reparar cpl.
3	1	1	1	1	1	1	1	1	1	1	027 245 010		Pumpenantrieb	Pump drive	Le commande de pompe	Propulsor de la bomba
4	1	1	1	1	1	1	1	1	1	1	930 916 160		Sprengring	Spring ring	Anneau ressort	Anillo elástico
5	1	1	1	1	1	1	1	1	1	1	001 245 320		Anschlagring	Stop ring	Bague de butée	Anillo de detención
6	1	1	1	1	1	1	1	1	1	1	020 245 020		Druckleitung, Öl	Pressure line	Conduite de pression	Conducto presión
7	1	1	1	1	1	1	1	1	1	1	020 245 040		Saugleitung, Öl, kpl.	Suction line, oil, assy.	Conduite d' aspir., cpl.	Conducto de aspir., cpl.
8	2	2	2	2	2	2	2	2	2	2	908 005 125		Schraube  M5x12	Screw	Vis	Tornillo
10	1	1	1	1	1	1	1	1	1	1	027 223 020		Kupplungstrommel	Clutch drum	Tambour	Tambor
11a	1	1	1	1	1	1	1	1	1	1	020 224 070		Zahnkranz .325", Z=8	Rim sprocket	Pignon	Piñón
11b	1	1	=	1	1	1	1	1	1	1	026 224 010		Zahnkranz 3/8", Z=7	Rim sprocket	Pignon	Piñón
12	1	1	1	1	1	1	1	1	1	1	962 210 025		Nadelkäfig 12x15x13	Needle cage	Cage à aiguilles	Jaula de agujas
13	1	1	1	1	1	1	1	1	1	1	027 245 020		Anlaufscheibe ø16,5x0,8	Stop disc	Disque portante	Disco de tope
15	1	1	1	1	1	1	1	1	1	1	027 245 111		Ölpumpe kpl. { 20b	Oil pump assy.	Pompe à huile cpl.	Bomba de aceite cpl.
16	1	1	1	1	1	1	1	1	1	1	957 245 320		Rep.-Satz Ölpumpe	Repair kit	Jeu de réparation	Juego de reparar
17	1	1	1	1	1	1	1	1	1	1	001 245 050		Ölpumpenkolben	Piston	Piston	Pistón
18	1	1	1	1	1	1	1	1	1	1	962 900 038		Radialdichtring	Radial ring	Joint radial	Anillo radial
19a	1	=	1	=	1	1					020 223 040		Kupplungstrommel mit Kettenrad .325", Z=8	Clutch drum w. sprocket	Tambour avec pignon	Tambor con piñón
19b	1	=	1	=	1	1					020 223 210		Kupplungstrommel mit Kettenrad 3/8", Z=7	Clutch drum w. sprocket	Tambour avec pignon	Tambor con piñón
20a	1		1								118 224 041	SI 12/94	Anlaufscheibe ø 44,0 mm (für Ölpumpe 027 245 110)	Stop disc (f. oil pump 027 245 110)	Disque portant (p. pompe à huile 027 245 110)	Disco de tope (p. bomba d. acei. 027 245 110)
20b	1		1		1	1					001 245 350	SI 12/94	Anlaufscheibe ø 36,5 mm (für Ölpumpe 027 245 111)	Stop disc (f. oil pump 027 245 111)	Disque portant (p. pompe à huile 027 245 111)	Disco de tope (p. bomba d. acei. 027 245 111)
21	=	1	=	1							020 223 101		Kupplungstrommel	Clutch drum	Tambour	Tambor
22		1		1							020 224 120		Anlaufscheibe ø 22,5 mm	Stop disc	Disque portant	Disco de tope
30	1	1	1	1		1	1				020 180 000		Kupplung kpl.	Clutch assy.	Embrayage cpl.	Embrague cpl.
31	2	2	2	2		2	2				112 184 111		Kupplungsblattfeder	Leaf spring ( clutch )	Ressort d' embrayage	Resorte de embrague
32	1	1	1	1		1	1				020 182 061		Spezialscheibe	Special spacer	Rondelle spéciale	Arandela especial
33	=	=	=	1							027 180 000		Kupplung kpl.	Clutch assy.	Embrayage cpl.	Embrague cpl.
34	=	=	=	1							122 184 011		Feder	Spring	Ressort	Muelle
35	=	=	=	1							027 182 030		Anlaufscheibe	Stop disc	Disque portant	Disco de tope
36	1	1	1	1	1	1	1	1	1	1	957 180 030		Kupplung kpl.	Clutch assy.	Embrayage cpl.	Embrague cpl.
37	3	3	3	3	3	3	3	3	3	3	024 184 021		Zugfeder	Tension spring	Ressort	Muelle
38	1	1	1	1	1	1	1	1	1	1	001 182 060		Führungsscheibe	Guide disc	Disque de guidage	Arandela





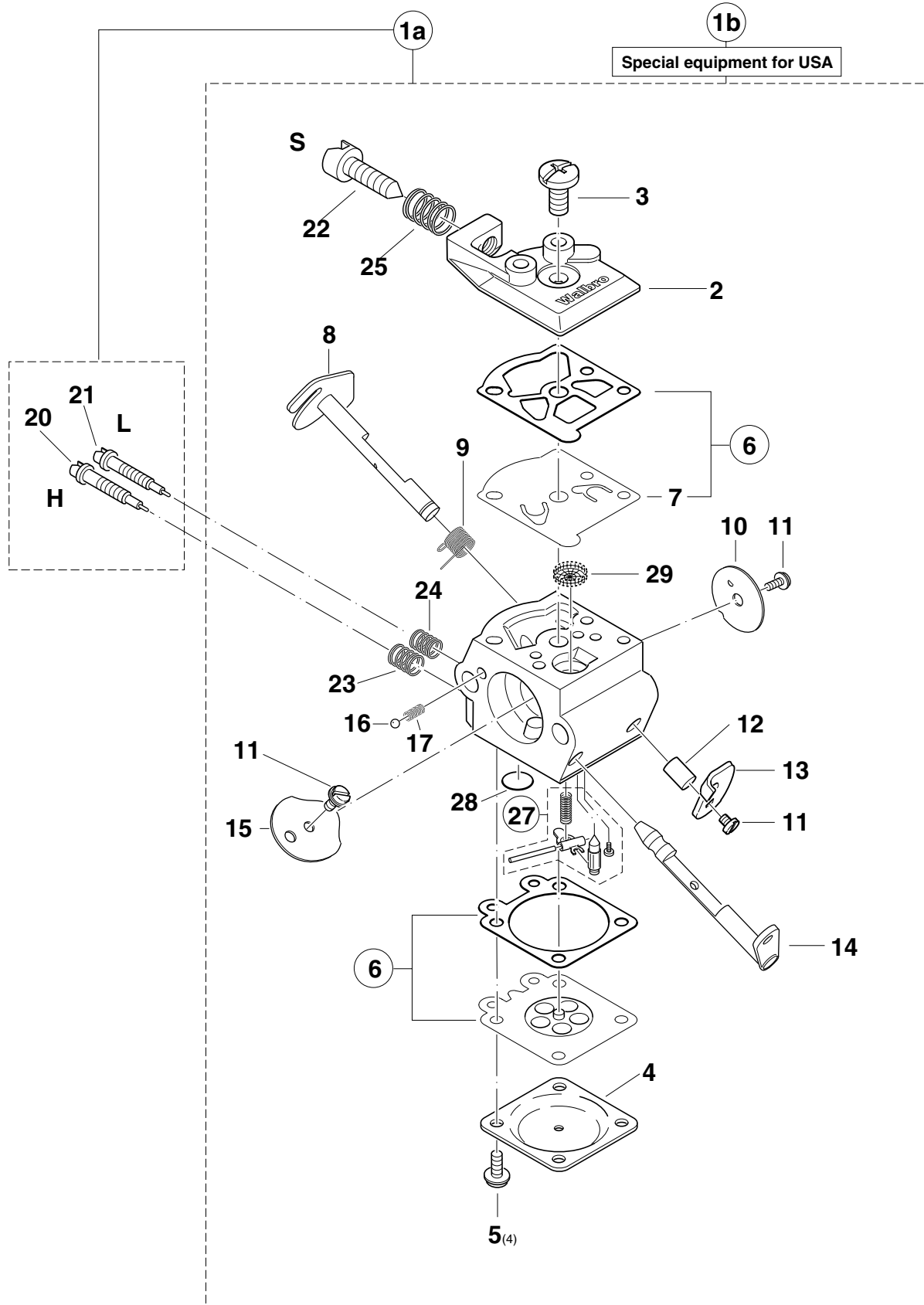

										<b>8</b>		<b>Abdeckhaube, Luftfilter, Schalldämpfer</b> <b>Hood, air filter, muffler</b> <b>Capot protecteur, filtre à air, pot d'échappement</b> <b>Cubierta protectora, filtro de aire, silencioso</b>				
Pos.	Anz. Qty. Qté. Cdad.									Teil-Nr. Part No. No. de pièce No. de pieza	Hinweise Notes Renseign. Nota	Benennung	Description	Désignation	Denominación	
1	1	1	1	1	1	1	1	1	1	1	027 118 154		Abdeckhaube	Hood	Capot	Tapa protectora
1		1									027 118 250	SI 5/96	Abdeckhaube	Hood	Capot	Tapa protectora
2	3	3	3	3	3	3	3	3	3	3	908 005 165		Schraube $\odot$ M5x16	Screw	Vis	Tornillo
3	1	1	1	1	1	1	1	1	1	1	020 118 121		Deckel kpl.	Cover assy.	Couvercle cpl.	Tapa cpl.
4	2	2	2	2	2	2	2	2	2	2	001 118 062		Mutter	Nut	Ecrou	Tuerca
5a	1	1	1	1	1	1	1	1	1	1	020 173 202		Luftfilter kpl. (Nylon)	Air filter cpl.	Filtre à air cpl.	Filtro de aire cpl.
5b	=	=	=	=	=	=	=	=	=	=	020 173 300		Luftfilter kpl. (Robkoflok)	Air filter cpl.	Filtre à air cpl.	Filtro de aire cpl.
6	2	2	2	2	2	2	2	2	2	2	908 605 145		Schlitz-Schraube $\odot$ M5x14	Screw	Vis	Tornillo
8	1	1	1	1	1	1	1	1	1	1	027 118 054		Boden	Bottom	Fond	Fondo
9	1	1	1	1	1	1	1	1	1	1	908 005 095		Schraube $\odot$ M5x9	Screw	Vis	Tornillo
10	1	1	1	1	1	1	1	1	1	1	965 401 024		Gummitülle	Rubber bush	Passe-fil	Boquilla de caucho
11	1	1	1	1	1	1	1	1	1	1	965 404 780		Dichtung	Gasket	Joint	Junta
12	1	1	1	1	1	1	1	1	1	1	965 525 032		Dichtung	Gasket	Joint	Junta
13	1	1	1	1	1	1	1	1	1	1	965 404 230		Stopfen (Vergaserheizung)	Plug (carb. heating)	Bouchon (chauff. de carb.)	Tapón (calef. de carb.)
14	1	1	1	1	1	1	1	1	1	1	965 404 410		Gummitülle	Rubber bush	Passe-fil	Boquilla de caucho
15	1	1	1	1	1	1	1	1	1	1	965 404 341		Dichtung	Gasket	Joint	Junta
16	1	1	1	1	1	1	1	1	1	1	020 131 041		Zwischenflansch	Intermediate flange	Bride intermédiaire	Brida intermedia
17	1	1	1	1	1	1	1	1	1	1	965 524 022		Dichtung	Gasket	Joint	Junta
18	1	1	1	1	1	1	1	1	1	1	020 171 100		Ansaugkrümmer	Connecting muff	Manchon de jonction	Manguito de con.
19	2	2	2	2	2	2	2	2	2	2	908 205 658		Schraube $\odot$ M5x65	Screw	Vis	Tornillo
20	2	2	2	2	2	2	2	2	2	2	924 105 300		Scheibe	Washer	Rondelle	Arandela
21	1	1	1	1	1	1	1	1	1	1	020 117 281		Gasgestänge kpl.	Throttle linkage cpl.	Tringle d'accélération	Varilla acelerador
22	1	1	1	1	1	1	1	1	1	1	020 118 030		Haubeneinsatz	Guide piece	Pièce de guidage	Pieza de guía
25	1	1	=	1	=	1	=	1	=	1	027 151 010		Vergaser kpl. WT 76	Carburetor cpl.	Carburateur cpl.	Carburador cpl.
26	1	1	1	1	1	1	1	1	1	1	027 150 830		Chokestange	Choke lever	Levier de starter	Palanca estrangul. aire
30	=	=	1	=	=	1	=	=	=	=	027 150 004		Injec.-Vergaser HU 83E	Injection carburetor	Carburateur d'injection	Carburador de inyección
31		1		1							027 150 880		Chokestange	Choke lever	Levier de starter	Palanca estrangul. aire
32		1		1							027 150 900		Klammer	Cramp	Crampon	Crampón
35	1	1	1	1	1	1	1	1	1	1	020 174 160		Schalldämpfer	Muffler	Pot d'échappement	Silencioso
36	1	1	1	1	1	1	1	1	1	1	965 522 032		Dichtung	Gasket	Joint	Junta
37	1	1	1	1	1	1	1	1	1	1	908 005 095		Schraube $\odot$ M5x9	Screw	Vis	Tornillo
38	2	2	2	2	2	2	2	2	2	2	908 205 625		Schraube $\odot$ M5x62	Screw	Vis	Tornillo
39	2	2	2	2	2	2	2	2	2	2	928 405 000		Spannscheibe	Spring washer	Rondelle ressort	Arandela
40	=	=	1	1	=	1	=	1	=	1	020 174 170		Abschirmblech	Heat shield	Tôle de protection	Chapa deflector
												<b>Spezialteile für USA</b>	<b>Special parts for USA</b>	<b>Pièces spéciales pour USA</b>	<b>Piezas especiales por USA</b>	
8	1	1	1							1	027 118 040		Boden (f. WT 374, 465)	Bottom	Fond	Fondo
25	1	1									027 151 020	=>	Vergaser kpl. WT 374	Carburetor cpl.	Carburateur cpl.	Carburador cpl.
25	1	1	1							1	027 151 020	=<	Vergaser kpl. WT 465	Carburetor cpl.	Carburateur cpl.	Carburador cpl.
30										1	027 150 010		Injec.-Vergaser HU 116 A	Injection carburetor	Carburateur d'injection	Carburador de inyección
45	1	1	1	1	1	1	1	1	1	1	020 174 202		Schalldämpfer kpl.	Muffler assy.	Pot d'échappement cpl.	Silencioso cpl.
46	1	1	1	1	1	1	1	1	1	1	020 174 110		Funkenschutzsieb	Spark arrester screen	Tamis	Tamiz
47	1	1	1	1	1	1	1	1	1	1	020 174 121		Leitblech	Deflection guard	Plaque de deviation	Placa de deviancion
48	1	1	1	1	1	1	1	1	1	1	915 042 130		Schraube 4,2x13	Screw	Vis	Tornillo

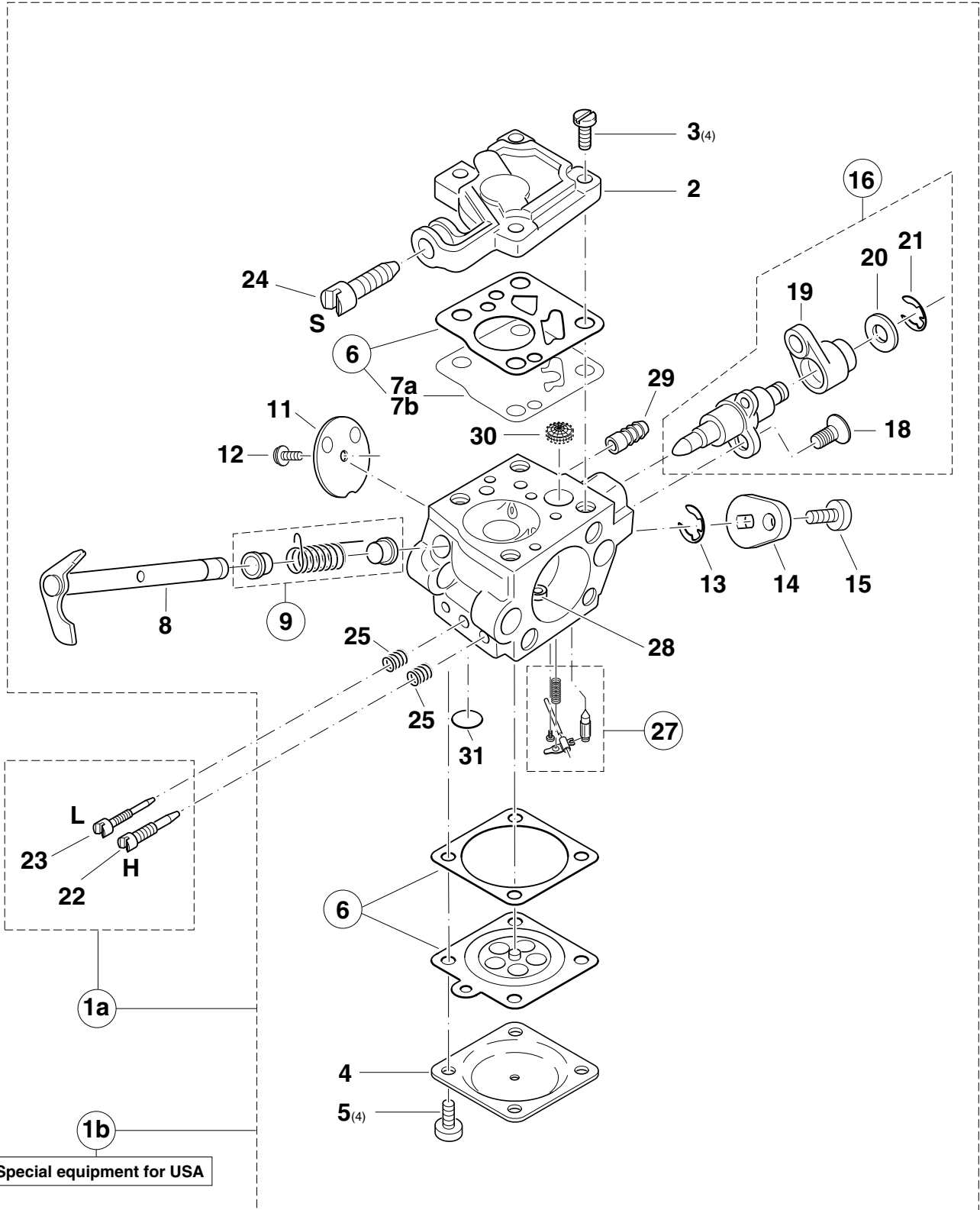

										<b>9</b>		Vergaser Carburetor Carburateur Carburador		WALBRO WT		<b>DOLMAR</b> 	
Pos.	Anz. Qty. Qté. Cdad.					Teil-Nr. Part No. No. de pièce No. de pieza	Hinweise Notes Renseign. Nota	Benennung	Description	Désignation	Denominación						
1a	1	1	=	1	1	027 151 010		Vergaser kpl. WT 76	Carburetor cpl.	Carburateur cpl.	Carburador cpl.						
2	1	1		1	1	001 151 165		Pumpendeckel	Pump cover	Couvercle de pompe	Tapa de bomba						
3	1	1		1	1	118 151 190		Schraube	Screw	Vis	Tornillo						
4	1	1		1	1	021 151 120		Membrandeckel	Diaphragm cover	Couvercle de membrane	Tapa de membrana						
5	4	4		4	1	118 151 020		Schraube	Screw	Vis	Tornillo						
6	1	1		1	1	021 151 540		Satz Dichtungen/Membran.	Set gaskets / diaphragm	Jeu de joints / membranes	Juega juntas / membranas						
7	1	1		1	1	021 151 150		Pumpenmembrane, Gummi	Pump diaphragm, rubber	Membr. de pompe, caoutch.	Membr. d. la bomba, caucho						
8	1	1		1	1	001 151 301		Drosselklappenwelle	Throttle shaft	Axe clapet d' étranglement	Eje válvula reg.						
9	1	1		1	1	001 151 310		Drehfeder	Spring	Ressort	Muelle						
10	1	1		1	1	021 151 320		Drosselklappe	Throttle shutter	Clapet d' étranglement	Válvula reg.						
11	3	3		3	1	118 151 060		Schraube	Screw	Vis	Tornillo						
12	1	1		1	1	001 151 580		Hülse	Sleeve	Douille	Manguito						
13	1	1		1	1	001 151 590		Hebel	Lever	Levier	Palanca						
14	1	1		1	1	001 151 600		Chokewelle	Choke shaft	Axe clapet d' aire	Eje válvula aire						
15	1	1		1	1	001 151 260		Chokeklappe	Choke shutter	Clapet d' aire	Válvula aire						
16	1	1		1	1	118 151 170		Arretierkugel	Friction ball	Bille de arrêt	Bola						
17	1	1		1	1	118 151 160		Arretierfeder	Friction spring	Ressort de arrêt	Muelle						
20	1	1		1	1	001 151 510		Vollgas-Stellschraube (H)	Main adjustm. screw	Vis de régl. d. plein gaz	Tornillo reg. máx.						
21	1	1		1	1	001 151 470		Leerlauf-Stellschraube (L)	Idling adjustm. screw	Vis de régl. de ralenti	Tornillo de tope ral.						
22	1	1		1	1	001 151 240		Leerlauf-Anschlagschr.(S)	Idle stop screw	Vis de butée de ralenti	Tornillo de toperalenti						
23	1	1		1	1	021 151 530		Feder (H)	Spring	Ressort	Muelle						
24	1	1		1	1	021 151 480		Feder (L)	Spring	Ressort	Muelle						
25	1	1		1	1	021 151 230		Feder (S)	Spring	Ressort	Muelle						
27	1	1		1	1	957 150 040		Satz Steuerteile	Set of control parts	Jeu de pièces de com.	Juego piezas de mando						
28	1	1		1	1	144 150 030		Verschlußscheibe	Cover disc	Disque de ferm.	Disco de cierre						
29	1	1		1	1	021 151 180		Sieb	Screen	Filtre	Tamiz						
								<b>Spezialteile für USA</b>	<b>Special parts for USA</b>	<b>Pièces spéciales pour USA</b>	<b>Piezas especiales por USA</b>						
1b	1	1				027 151 020	=>	Vergaser kpl. WT 374	Carburetor cpl.	Carburateur cpl.	Carburador cpl.						
1b	1	1		1		027 151 020	<=	Vergaser kpl. WT 465	Carburetor cpl.	Carburateur cpl.	Carburador cpl.						



										<b>10</b>		Vergaser Carburetor Carburateur Carburador		TILLOTSON HU - Injection		<b>DOLMAR</b> 	
Pos.	Anz. Qty. Qté. Cdad.					Teil-Nr. Part No. No. de pièce No. de pieza	Hinweise Notes Renseign. Nota	Benennung	Description	Désignation	Denominación						
1a	=	=	1	=	=	027 150 004		Vergaser kpl. HU 83 E	Carburetor cpl.	Carburateur cpl.	Carburador cpl.						
2		1	1			020 150 160		Pumpendeckel	Pump cover	Couvercle de pompe	Tapa de bomba						
3		4	4			020 150 170		Zylinderschraube	Fillister head screw	Vis cylindrique	Tornillo cilíndrico						
4		1	1			104 150 120		Membrandeckel	Diaphragm cover	Couvercle de membrane	Tapa de membrana						
5		4	4			001 150 620		Schraube	Screw	Vis	Tornillo						
6		1	1			957 150 080		Membransatz TILL. HU Gummi	Set gaskets / diaphragm	Jeu de joints / membranes	Juego juntas / membranas						
7a		1	1			100 150 150		Pumpenmembrane, Gummi	Pump diaphr., rubber	Membr. de pompe, caoutch.	Membr. d. la bomba, caucho						
7b		=	=			001 150 640		Pumpenmembrane, Mylar	Pump diaphr., mylar	Membr. de pompe, mylar	Membr. d. la bomba, mylar						
8		1	1			001 150 610		Drosselklappenwelle	Throttle shaft	Axe clapet d' étranglement	Eje válvula reg.						
9		1	1			957 150 310		Drehfeder kpl.	Spring cpl.	Ressort cpl.	Muelle cpl.						
11		1	1			001 150 321		Drosselklappe	Throttle shutter	Clapet d' étranglement	Válvula reg.						
12		1	1			001 150 650		Schraube	Screw	Vis	Tornillo						
13		1	1			100 150 350		Sicherungsring	Safety washer	Rondelle sécurité	Arandela seguridad						
14		1	1			020 150 330		Hebel	Lever	Levier	Palanca						
15		1	1			001 150 680		Schraube	Screw	Vis	Tornillo						
16 cpl.		1	1			001 150 170		Injektionsventil kpl.	Injection valve cpl.	Soupape d' injection cpl.	Válvula p. inyecciones						
18		1	1			113 150 220		Schraube	Screw	Vis	Tornillo						
19		1	1			027 150 860		Hebel	Lever	Levier	Palanca						
20		1	1			001 150 670		Scheibe	Washer	Rondelle	Arandela						
21		1	1			119 150 350		Sicherungsring	Safety washer	Rondelle sécurité	Arandela seguridad						
22		1	1			020 150 520		Vollgas-Stellschraube (H)	Main adjustm. screw	Vis de régl. d. plein gaz	Tornillo reg. máx.						
23		1	1			020 150 470		Leerlauf-Stellschraube (L)	Idling adjustm. screw	Vis de régl. de ralenti	Tornillo de tope ral.						
24		1	1			020 150 240		Leerlauf-Anschlagschr.(S)	Idle stop screw	Vis de butée de ralenti	Tornillo de toperalenti						
25		2	2			001 150 480		Feder	Spring	Ressort	Muelle						
27		1	1			957 150 150		Satz Steuerteile	Set of control parts	Jeu de pièces de com.	Juego piezas de mando						
28		1	1			020 150 130		Hauptdüse	Main nozzle	Buse	Tobera						
29		1	1			020 150 051		Anschlußnippel	Conecting fitting	Raccord	Niple de conexión						
30		1	1			020 150 180		Sieb	Screen	Filtre	Tamiz						
31		1	1			100 150 040		Verschlusscheibe	Cover disc	Disque de ferm.	Disco de cierre						
								<b>Spezialteile für USA</b>	<b>Special parts for USA</b>	<b>Pièces spéciales pour USA</b>	<b>Piezas especiales por USA</b>						
1b			1			027 150 010		Vergaser kpl. HU 116 A	Carburetor cpl.	Carburateur cpl.	Carburador cpl.						

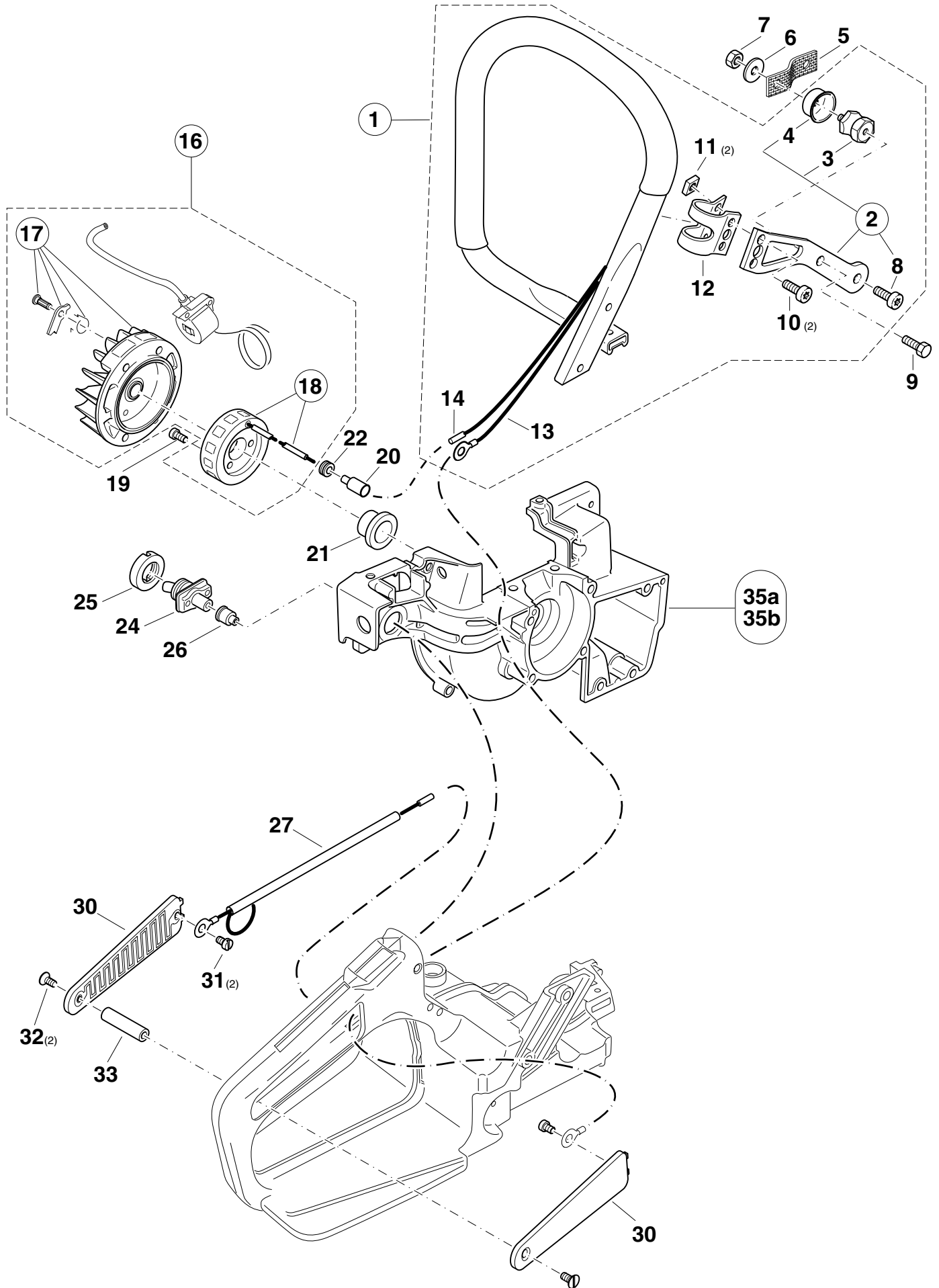

109  
109 HappyStart  
110i  
111  
115  
115i  
PS-43  
PS-52  
PS-540

11

Spezialteile für Ausführung mit elektrischer Heizung  
Special parts for version with electric handle heating  
Pièces spéciales pour version avec chauffage de la poignée (électrique)  
Piezas especiales por tipo con calefacción eléctrica de mango



Pos.	Anz. Qty. Qté. Cdad.	Teil-Nr. Part No. No. de pièce No. de pieza	Hinweise Notes Renseign. Nota	Benennung	Description	Désignation	Denominación
1	1	1		Bügelgriff kpl.	Tubular handle assy.	Poignée tubulaire cpl.	Mango tubular cpl.
2	1	1		Stütze kpl.	Bracket cpl.	Support cpl.	Soporte cpl.
3	1	1		Schwingungsdämpfer	Rubber buffer	Amortisseur	Amortiguador
4	1	1		Topf	Pot	Capuchon	Pote
5	1	1		AbreiÙsicherung	Safety-catch wire	Sûreté countre-rupture	Chapa seguridad
6	1	1		Scheibe	Disc	Disque	Arandela
7	1	1		6kt-Mutter M5	Hexagonal nut	Ecrou hexagonal	Tuerca hexagonal
8	1	1		Zyl.-Schraube M5x9	Fillister head screw	Vis cylindrique	Tornillo cilíndrico
9	1	1		6kt-Schraube M5x8	Hex. head screw	Vis hexagonal	Tornillo hex.
10	2	2		Zyl.-Schraube M5x12	Fillister head screw	Vis cylindrique	Tornillo cilíndrico
11	2	2		4kt-Mutter M5	Square nut	Ecrou carré	Tuerca cuadrada
12	1	1		Schelle	Clamp	Collier	Abrazadera
13	1	1		Kabel kpl.	Cable cpl.	Câble cpl.	Cable cpl.
14	1	1		Rundsteckverbinder	Circular connector	Fiche ronde mâle	Conexión por enchufe
16	1	1		Magnetzûnder kpl.	Ignition assy.	Volant magn. cpl..	Dispos. enc. magn.
17	1	1		Polrad kpl.	Flywheel	Roue polaire	Volante encend.
18	1	1		Generatoranker	Generator coil	Bobine générateur	Bobina generador
19	3	3		Zyl.-Schraube M4x14	Fillister head screw	Vis cylindrique	Tornillo cilíndrico
20	1	1		Rundsteckhûlse	Circular socket	Fiche ronde femelle	Conexion po enchufe
21	1	1		Buchse zum Zentrieren	Bushing for centralize	Douille de centrage	Casquillo de centrar
22	1	1		Gummitûlle	Rubber bush	Passe-fil	Boquilla de caucho
24	1	1		Schalter	Switch	Interrupteur	Interruptor
25	1	1		Mutter	Nut	Ecrou	Tuerca
26	1	1		Gummitûlle	Rubber bush	Passe-fil	Boquilla de caucho
27	1	1		Kabel kpl.	Cabel assy.	Câble cpl.	Cable cpl.
30	2	2		Griffschale kpl.	Grip plate assy.	Plaque de poignée cpl.	Chapa de mango cpl.
31	2	2		Blechschrabe 2,9x4,5	Screw	Vis	Tornillo
32	2	2		Senkschrabe M3x6	Counter sunk screw	Vis fraisée	Tornillo plano
33	1	1		Buchse	Bush	Douille	Casquillo
35b	1	1	=>	Kurbelgehäuse MS	Crankcase mag. side	Carter-coté magn.	Cárter cig., lado magn.
35b	1	1	=<	Kurbelgehäuse MS	Crankcase mag. side	Carter-coté magn.	Cárter cig., lado magn.
				<b>110i H: → 124759</b>	<b>115i H: → 185116</b>		
35a	1	1		Kurbelgehäuse MS kpl. { 22, Seite 3a: 4, 8	Crankcase cpl. (mag.) { 22, page 3a: 4, 8	Carter-coté magn. cpl. { 22, page 3a: 4, 8	Cárter cig., lado magn. cpl. { 22, page 3a: 4, 8



Length	Pitch	Gauge	GUIDE BAR	SAW CHAIN	REPLACEMENT NOSE SPROCKET		
			part no.	part no.	teeth	part no. (pos. 6a)	part no. (pos. 6b)
<b>Guide bar and saw chain combinations meeting kickback requirements of ANSI B 175.1 for the use in the USA</b>							
<b>Models DOLMAR 109, 109 HappyStart, 110i, 111, 111i, 115i, PS-540 - chain sprocket: .325" / 8 teeth</b>							
15" / 38 cm	.325"	.058"	411 407 600 =>	523 085 064	10	411 406 700	-
15" / 38 cm	.325"	.058"	415 038 631 <=>	523 085 064	10	-	415 325 710
16" / 40 cm	.325"	.058"	415 040 631	523 085 066	10	-	415 325 710
18" / 45 cm	.325"	.058"	411 409 600 =>	523 085 072	10	411 406 700	-
18" / 45 cm	.325"	.058"	415 045 631 <=>	523 085 072	10	-	415 325 710
<b>Models DOLMAR 111, 111i, 115i, PS-540 - chain sprocket: 3/8" / 7 teeth</b>							
18" / 45 cm	3/8"	.050"	411 909 660	523 102 064	11	-	415 038 730
21" / 53 cm	3/8"	.050"	411 910 660	523 102 072	11	-	415 038 730
<b>Guide bar and saw chain combinations meeting kickback requirements of CSA Z62.3 for the use in CANADA</b>							
<b>Models DOLMAR 109, 109 HappyStart, 110i, 111i, 115i, PS-540 - chain sprocket: .325" / 8 teeth</b>							
15" / 38 cm	.325"	.058"	411 407 600 =>	523 085 064	10	411 406 700	-
15" / 38 cm	.325"	.058"	415 038 631 <=>	523 085 064	10	-	415 325 710
16" / 40 cm	.325"	.058"	415 040 631	523 085 066	10	-	415 325 710
18" / 45 cm	.325"	.058"	411 409 600 =>	523 085 072	10	411 406 700	-
18" / 45 cm	.325"	.058"	415 045 631 <=>	523 085 072	10	-	415 325 710
<b>Models DOLMAR 109, 109 HappyStart, 110i, 111i, 115i, PS-540 - chain sprocket: 3/8" / 7 teeth</b>							
15" / 38 cm	3/8"	.058"	411 907 650	522 094 056	11	412 308 700	415 038 720
18" / 45 cm	3/8"	.058"	411 909 650	522 094 064	11	412 308 700	415 038 720
21" / 53 cm	3/8"	.058"	411 910 650	522 094 072	11	412 308 700	415 038 720

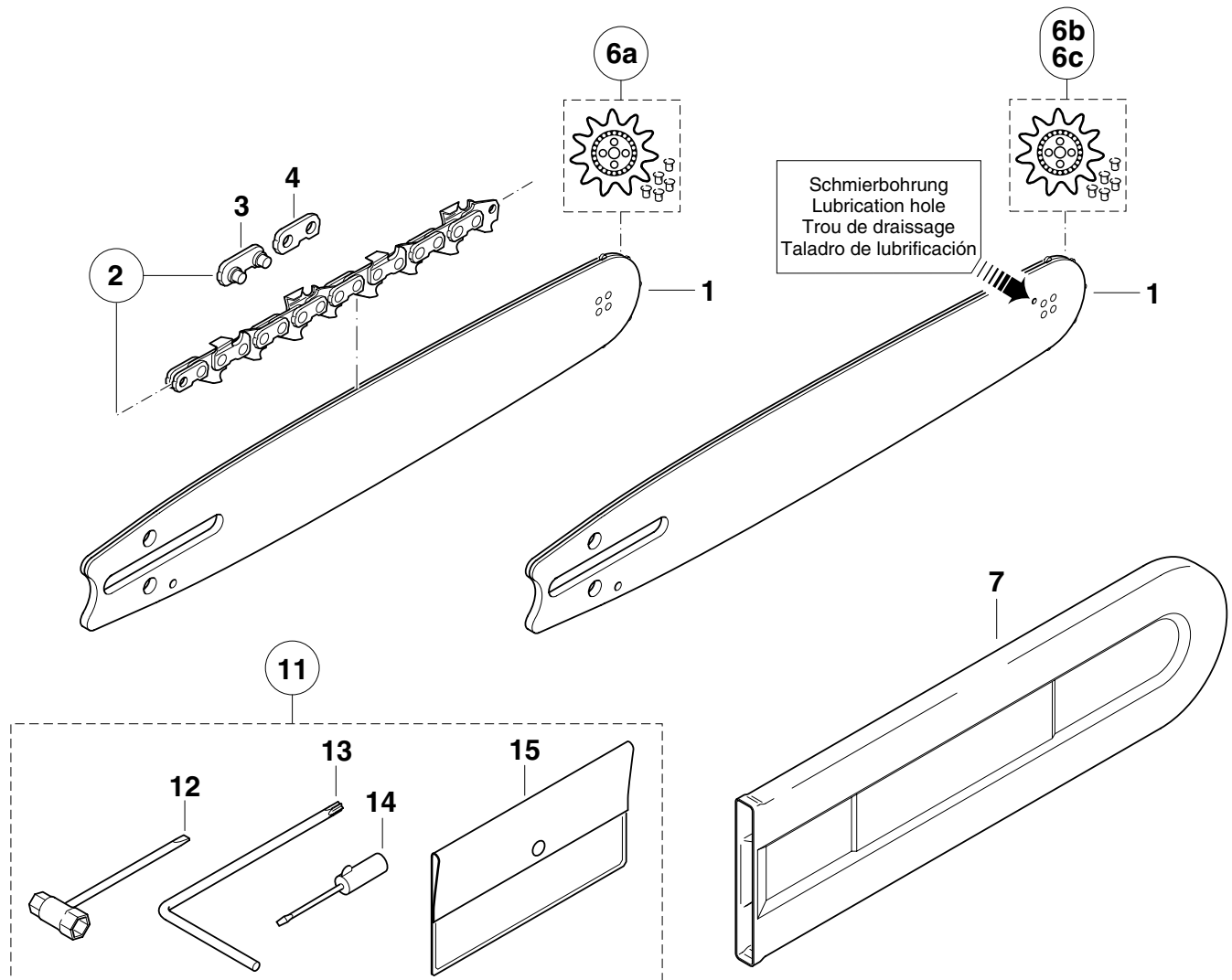



109 HappyStart  
1101  
111  
115  
115f  
PS-43  
PS-52  
PS-540

12

Sägeschienen, Sägeketten, Werkzeug  
Guide bars, saw chains, tools  
Guide-chaîne, chaînes, outils  
Rieles guía, cadenas sierra, herramientas



Pos.	Anz. Qty. Qté. Cdad.	Teil-Nr. Part No. No. de pièce No. de pieza	Hinweise Notes Renseign. Nota	Benennung	Description	Désignation	Denominación
			1,5mm	<b>Sternschiene .325"</b>	<b>Sprocket nose bar .325"</b>	<b>Guide à étoile .325"</b>	<b>Barra guía .325"</b>
1	1 1 1 1 1 1 1 1 1 1	432 033 030	=>	Sternschiene 33 cm / 13"	Sprocket nose bar	Guide à étoile	Barra guía
1	1 1 1 1 1 1 1 1 1 1	411 407 600	=>	Sternschiene 38 cm / 15"	Sprocket nose bar	Guide à étoile	Barra guía
1	1 1 1 1 1 1 1 1 1 1	411 409 600	=>	Sternschiene 45 cm / 18"	Sprocket nose bar	Guide à étoile	Barra guía
1	1 1 1 1 1 1 1 1 1 1	415 033 631	<=>	Sternschiene 33 cm / 13"	Sprocket nose bar	Guide à étoile	Barra guía
1	1 1 1 1 1 1 1 1 1 1	415 038 631	<=>	Sternschiene 38 cm / 15"	Sprocket nose bar	Guide à étoile	Barra guía
1	1 1 1 1 1 1 1 1 1 1	415 040 631	<=>	Sternschiene 40 cm / 16"	Sprocket nose bar	Guide à étoile	Barra guía
1	1 1 1 1 1 1 1 1 1 1	415 045 631	<=>	Sternschiene 45 cm / 18"	Sprocket nose bar	Guide à étoile	Barra guía
			1,5mm	<b>Sternschiene 3/8"</b>	<b>Sprocket nose bar 3/8"</b>	<b>Guide à étoile 3/8"</b>	<b>Barra guía 3/8"</b>
1	1 1 1 1 1 1 1 1 1 1	411 907 650		Sternschiene 38 cm / 15"	Sprocket nose bar	Guide à étoile	Barra guía
1	1 1 1 1 1 1 1 1 1 1	411 909 650		Sternschiene 45 cm / 18"	Sprocket nose bar	Guide à étoile	Barra guía
			1,5mm	<b>Sägekette 086 / .325"</b>	<b>Saw chain 086 / .325"</b>	<b>Chaîne 086 / .325"</b>	<b>Cadena 086 / .325"</b>
2	1 1 1 1 1 1 1 1 1 1	528 086 056		Sägekette (33 cm / 13")	Saw chain	Chaîne	Cadena
2	1 1 1 1 1 1 1 1 1 1	528 086 064		Sägekette (38 cm / 15")	Saw chain	Chaîne	Cadena
2	1 1 1 1 1 1 1 1 1 1	528 086 066		Sägekette (40 cm / 16")	Saw chain	Chaîne	Cadena
2	1 1 1 1 1 1 1 1 1 1	528 086 072		Sägekette (45 cm / 18")	Saw chain	Chaîne	Cadena
3		558 083 010		Außenlasche mit Niet	Tie strap with rivets	Eclisse avec rivets	Tira ext. con remache
4		558 083 000		Außenlasche	Tie strap	Eclisse extérieure	Tira ext.
			1,5mm	<b>Sägekette 093 / 3/8"</b>	<b>Saw chain 093 / 3/8"</b>	<b>Chaîne 093 / 3/8"</b>	<b>Cadena 093 / 3/8"</b>
2	1 1 1 1 1 1 1 1 1 1	523 093 056		Sägekette (38 cm / 15")	Saw chain	Chaîne	Cadena
2	1 1 1 1 1 1 1 1 1 1	523 093 064		Sägekette (45 cm / 18")	Saw chain	Chaîne	Cadena
3		558 093 010		Außenlasche mit Niet	Tie strap with rivets	Eclisse avec rivets	Tira ext. con remache
4		558 093 000		Außenlasche	Tie strap	Eclisse extérieure	Tira ext.
			1,5mm	<b>Sägekette 099 / 3/8"</b>	<b>Saw chain 099 / 3/8"</b>	<b>Chaîne 099 / 3/8"</b>	<b>Cadena 099 / 3/8"</b>
2	1 1 1 1 1 1 1 1 1 1	528 099 056		Sägekette (38 cm / 15")	Saw chain	Chaîne	Cadena
2	1 1 1 1 1 1 1 1 1 1	528 099 064		Sägekette (45 cm / 18")	Saw chain	Chaîne	Cadena
3		558 093 010		Außenlasche mit Niet	Tie strap with rivets	Eclisse avec rivets	Tira ext. con remache
4		558 093 000		Außenlasche	Tie strap	Eclisse extérieure	Tira ext.
6a	1 1 1 1 1 1 1 1 1 1	411 406 700	1,5mm	Umlenkstern kpl. .325"	Sprocket nose cpl.	Etoile cpl.	Estrella cpl.
6a	1 1 1 1 1 1 1 1 1 1	412 308 700	1,5mm	Umlenkstern kpl. 3/8"	Sprocket nose cpl.	Etoile cpl.	Estrella cpl.
6b	1 1 1 1 1 1 1 1 1 1	415 325 710	1,5mm	Umlenkstern kpl. .325"	Sprocket nose cpl.	Etoile cpl.	Estrella cpl.
6b	1 1 1 1 1 1 1 1 1 1	415 038 720	1,5mm	Umlenkstern kpl. 3/8"	Sprocket nose cpl.	Etoile cpl.	Estrella cpl.
7	1 1 1 1 1 1 1 1 1 1	952 100 133		Sägekettenschutz 33 cm	Chain prot. cover 13"	Enveloppe protectrice	Estuche protector
7	1 1 1 1 1 1 1 1 1 1	952 100 143		Sägekettenschutz 38-45cm	Chain prot. cover 15"-18"	Enveloppe protectrice	Estuche protector
11	1 1 1 1 1 1 1 1 1 1	957 004 002		Werkzeug kpl.	Tools cpl.	Outils cpl.	Herramientas cpl.
12	1 1 1 1 1 1 1 1 1 1	941 719 131		Kombischlüssel SW 19/13	Universal wrench	Clé combinée	Llave de buja
13	1 1 1 1 1 1 1 1 1 1	940 827 000		Winkelschraubendreher	Angled screw driver	Clé angle	Llave angular
14	1 1 1 1 1 1 1 1 1 1	944 340 001		Schraubendreher	Screw driver	Tournevis	Destornillador
15	1 1 1 1 1 1 1 1 1 1	950 004 001		Werkzeugtasche	Plastik bag	Pochette en plastique	Cartera herramientas
				<b>Zubehör (nicht im Lieferumfang)</b>	<b>Accessories (not incl. in delivery)</b>	<b>Accessoires (non incl. dans la livraison)</b>	<b>Accesorios (no incluidos en entrega)</b>
			1,3mm	<b>Sternschiene .325"</b> für Sägekette 484	<b>Sprocket nose bar .325"</b> for saw chain 484	<b>Guide à étoile .325"</b> pour chaîne 484	<b>Barra guía .325"</b> por cadena 484
1	1 1 1 1 1 1 1 1 1 1	415 033 141		Sternschiene 33 cm / 13"	Sprocket nose bar	Guide à étoile	Barra guía
1	1 1 1 1 1 1 1 1 1 1	415 038 141		Sternschiene 38 cm / 15"	Sprocket nose bar	Guide à étoile	Barra guía
1	1 1 1 1 1 1 1 1 1 1	415 045 141		Sternschiene 45 cm / 18"	Sprocket nose bar	Guide à étoile	Barra guía
			1,3mm	<b>Sägekette 484 / .325"</b>	<b>Saw chain 484 / .325"</b>	<b>Chaîne 484 / .325"</b>	<b>Cadena 484 / .325"</b>
2	1 1 1 1 1 1 1 1 1 1	512 484 056		Sägekette (33 cm / 13")	Saw chain	Chaîne	Cadena
2	1 1 1 1 1 1 1 1 1 1	512 484 064		Sägekette (38 cm / 15")	Saw chain	Chaîne	Cadena
2	1 1 1 1 1 1 1 1 1 1	512 484 072		Sägekette (45 cm / 18")	Saw chain	Chaîne	Cadena
3		510 084 020		Außenlasche mit Niet	Tie strap with rivets	Eclisse avec rivets	Tira ext. con remache
4		510 084 040		Außenlasche	Tie strap	Eclisse extérieure	Tira ext.
6c	1 1 1 1 1 1 1 1 1 1	415 325 740	1,3mm	Umlenkstern kpl. .325"	Sprocket nose cpl.	Etoile cpl.	Estrella cpl.

109, 109 HappyStart 110i, 110i H 111 115, 115 H, 115i, 115i H PS-43, PS-52, PS-540	<b>1</b>	<b>Inhaltsverzeichnis Table des matières</b>	<b>Index Indice</b>	<b>DOLMAR</b> 
--	----------	--	-------------------------	--

<b>2</b>	Zylinder, Kolben Cylindre, piston	Cylinder, piston Cilindro, piston
<b>3a - 3b</b>	Kurbelgehäuse Carter- vilebrequin	Crankcase Carter cigüeñal
<b>4</b>	Kraftstofftank, Bügelgriff Réserv. carburant, poignée tubulaire	Fuel tank, tubular grip Depósito de combustible, mango tubular
<b>5</b>	Zündelektronik, Anwerfvorrichtung Allumage électr., dispos. de démarrage	Ignition electronics, starter Bobina encendido, dispositivo de arranque
<b>6</b>	Kettenbremse, Handschutz Frein de chaîne, protège-main	Chain brake, hand guard Freno de cadena, protector de mano
<b>7</b>	Ölpumpe, Kupplung Pompe à huile, embrayage	Oil pump, clutch Bomba de aceite, embrague
<b>8</b>	Abdeckhaube, Luftfilter, Schalldämpfer Capot protecteur, filtre à air, pot d' échappement	Hood, air filter, muffler Cubierta protectora, filtro de aire, silencioso
<b>9</b>	Vergaser WT Carburateur WT	Carburetor WT Carburador WT
<b>10</b>	Vergaser HU (injection) Carburateur HU (injection)	Carburetor HU (injection) Carburador HU (injection)
<b>11</b>	Spezialteile für Ausrüstung mit elektrischer Heizung Pièces spéc. p. vers. a. chauffage de la poignée (électrique)	Special parts for version with electric handle heating Piezas especiales por tipo con calefacción eléctric de mango
<b>12</b>	Sägeschienen, Sägeketten, Werkzeug Guide-chaîne, chaînes, outils	Guide bars, saw chains, tools Rieles guía, cadenas sierra, herramientas

	<b>Zeichenerklärung</b>	<b>Key to symbols</b>	<b>Légende</b>
⇒ 1999999 2000000 ⇒ 4/95 ⇒ SI 5/95 => xxx = { m* ⊗ Corr.	Produktion bis Serien-Nr. Neues Teil ab Serien-Nr. Neues Teil ab Monat / Jahr Siehe Service-Information Monat / Jahr Teil gleichwertig ersetzt Nicht mehr lieferbar Keine Serienausführung, jedoch verwendbar Beinhaltet Positions-Nr. Meterware Innensternschraube Druckfehlerberichtigung	Production to serial number New part from serial number New part from Month / Year See Service-Information Month / Year Modified part No more available No standard execution, may be used Contains item no. Sold by the meter Star socket screw Error correction	Production jusqu'à n° de série Nouveau pièce à partir du n° de série Nouveau pièce à partir de Mois / Année Voir Service-Information Mois / Année Pièce modifiée Plus livrable Aucune exécut. en série, cependant utilisable contient n° de numéro Au mètre Vis à étoile intérieure Rectification d' erreurs

	<b>Explicación de símbolos</b>	<b>Verklaring der tekens</b>	<b>Chiarificazione dei simboli</b>
⇒ 1999999 2000000 ⇒ 4/95 ⇒ SI 5/95 => xxx = { m* ⊗ Corr.	Producción hasta N° de serie Pieza nueva a partir de N° de serie Pieza nueva a partir de mes / año Véase inform. servicio mes / año Pieza modificada Agotado No es de serie, pero sirve Contiene pos N° Por metro Tornillo estrella interior Fe de erratas	In productie tot serie-Nr. Nieuw onderdeel vanaf serie-Nr. Nieuw onderdeel vanaf maand / jaar Zie service-informatie maand / jaar Vervangen door gelijkwaardig onderdeel Niet meer leverbaar Geen serieuitvoering, maar wel bruikbaar Omvat Positie-Nr. Metergoed Binnen-ster schroef Drukfoutcorrectie	Produzione fino al n. di serie Nuovo pezzo a partire dal n. di serie Nuovo pezzo a partire dal mese / anno Vedere il servizio inform. del mese / anno Pezzo sostituito con un pezzo equivalente Non più disponibile Non è un modello di serie, ma ugualm. utilizza. Comprende la posizione n. Articoli a metraggio Vite con intaglio a stella Rettifica di errori di stampa

	<b>Tegnforklaring</b>	<b>Teckenförklaring</b>	<b>Merkklen selvitys</b>
⇒ 1999999 2000000 ⇒ 4/95 ⇒ SI 5/95 => xxx = { m* ⊗ Corr.	Produktion indtil løbenr. Ny del fra og med løbenr. Ny del fra og med måned / år Se Service-Information måned / år Afløst med tilsvarende del Kan ikke leveres mere Ikke standardudgave, men kan anvendes Inkluderer position nr. Metervare Skruer med indiv. stjerne Rettelse af trykfejl	Produktion t o m serienr Ny detalj fr o m serienr Ny detalj fr o m måned / år Se serviceinformation måned / år Ersatt med motsvarande detalj Kan ej mera levereras Ej serieutförande, men användbar Innehåller positionsnr Metervara Skruv med stjärnspår Korrigerig av tryckfel	Tuotanto sarjanumeroon ... asti Uusi osa alkaen sarjanumerosta Uusi osa alkaen kuukausi / vuosi Katso huolto-ohje kuukausi / vuosi Osa vaihdettu vastaavaan Ei enää toimitettavissa Ei sarjavalmistusta, voidaan kuitenkin käyttää Positionumero sisältyy Metritavara Tähtikoloruuvit Painovirheen oikaisu